

CUSTOMER ORDER NO: -----

3 STAGE REDUCER

MODEL NUMBER: 150K

OVERALL RATIO: -----:1

AGMA CLASS 1 RATING: ----- HP @ ----- RPM

SERVICE FACTOR: -----

1245 Lbs.

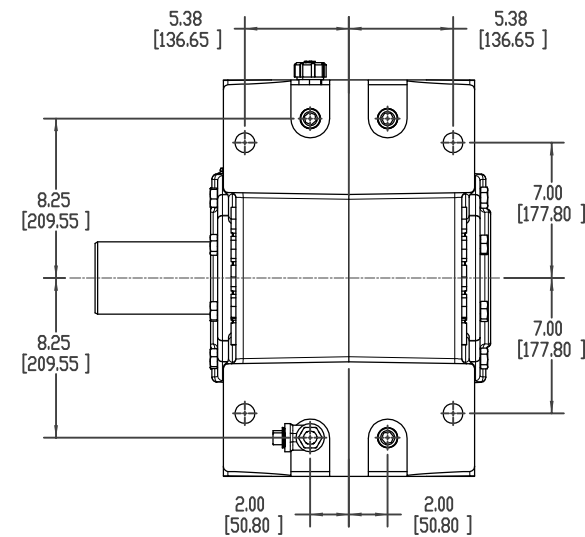
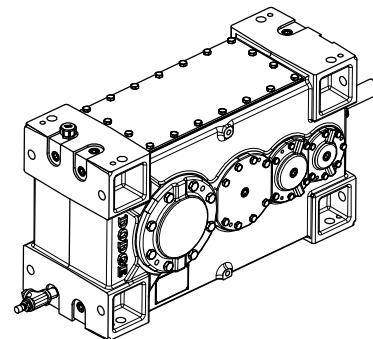
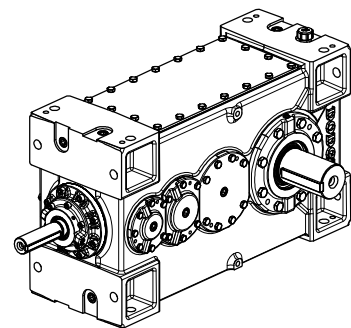

LOW SPEED
END VIEW

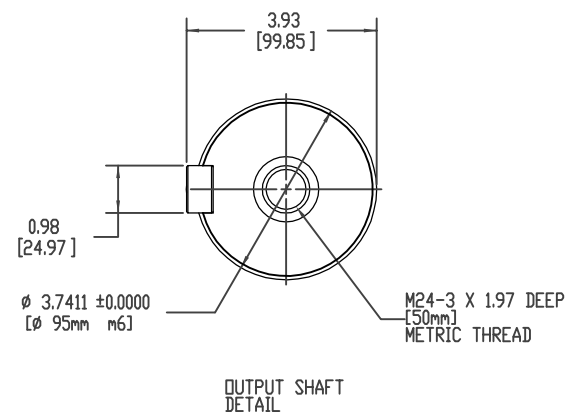
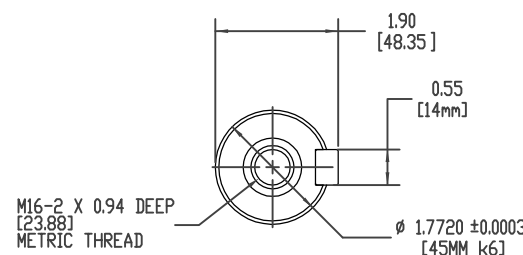
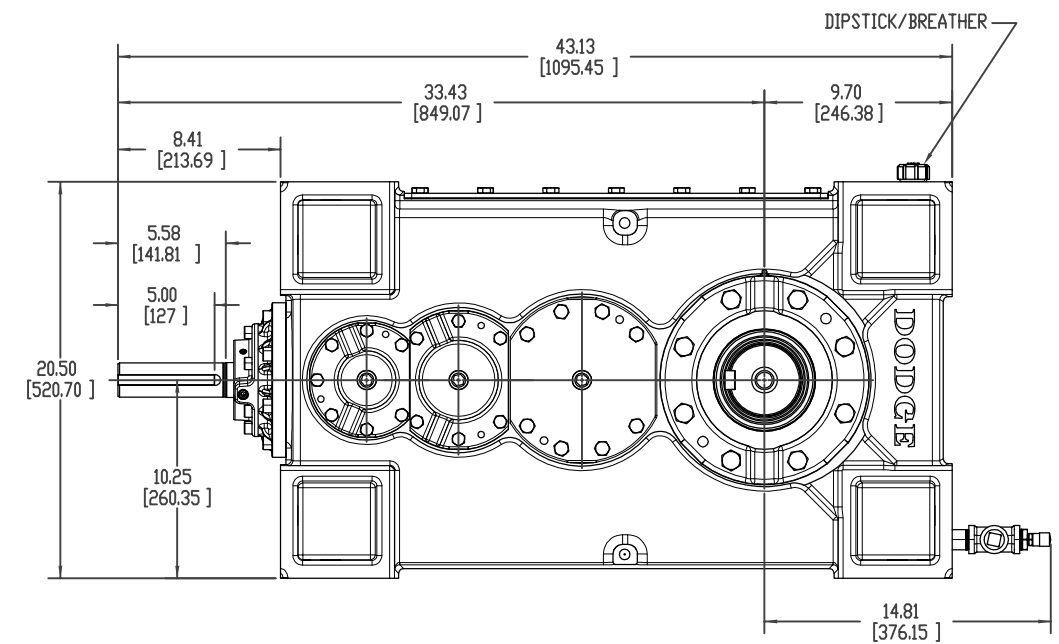
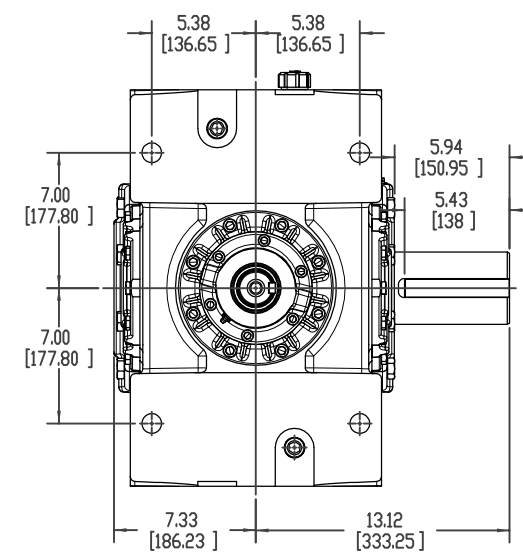
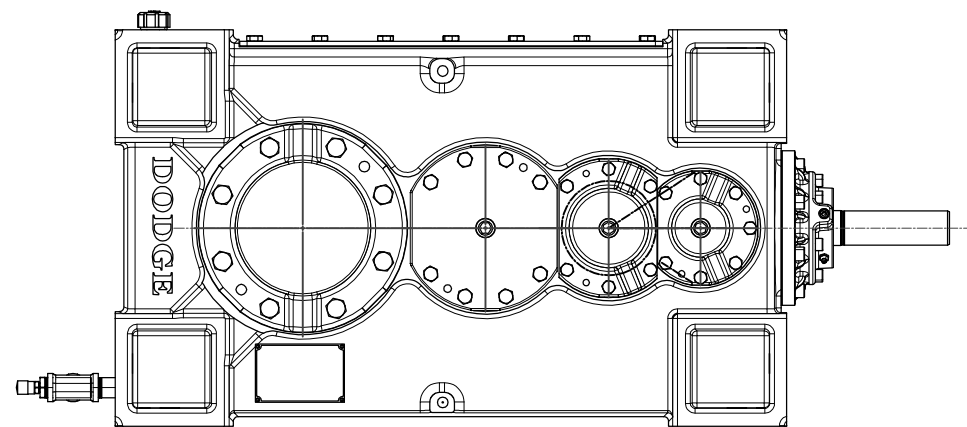
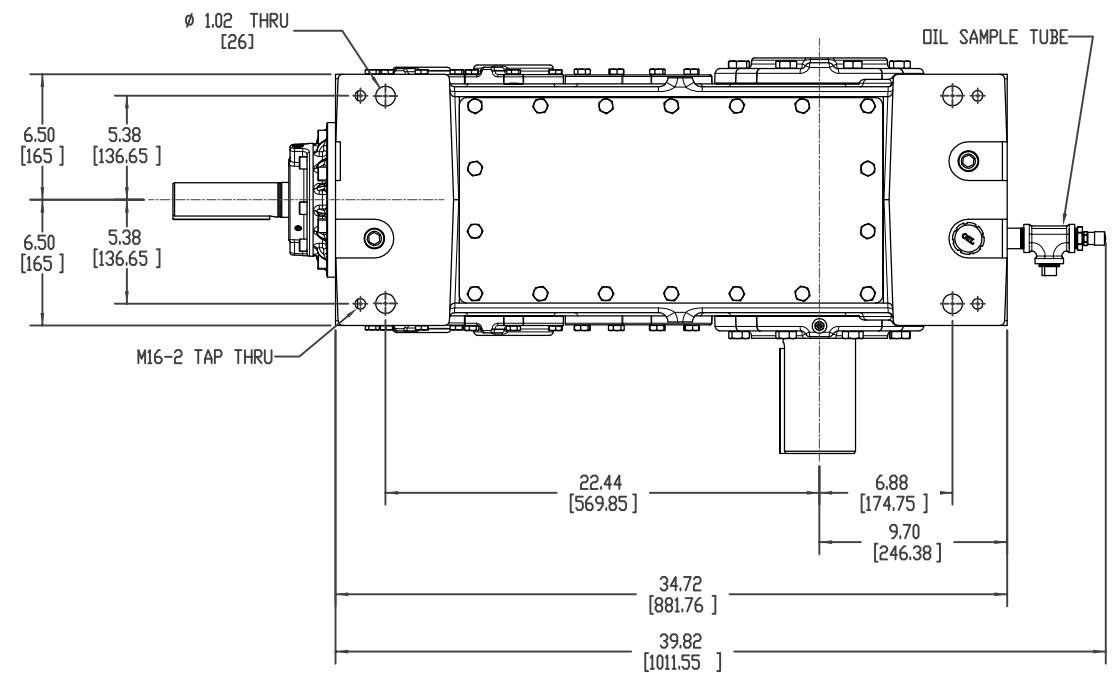

BALDOR-DODGE-RELIANCE PROPRIETARY & CONFIDENTIAL THIS DRAWING IS THE PROPERTY OF BALDOR-DODGE-RELIANCE AND/OR ITS SUBSIDIARIES AND IS NOT TO BE USED, DUPLICATED OR DISCLOSED WITHOUT THE EXPRESS WRITTEN PERMISSION OF THE COMPANY.									
ECR#485	A	3/3/09	BL	RG	CHANGED BOM CHART FROM 452267 TO 453382	REVISION DESCRIPTION			
MATERIAL 7/28/08	DIMENSION TOLERANCE UNLESS OTHERWISE SPECIFIED				PRODUCT MAGNAGEAR 100K	BEST			
CASTING OR FORGING NO.	MACHINE TOL PER S022 FABRICATION TOL PER S356 CASTING TOL PER S249 - BRK ALL SHRP CORNERS 0.005-0.015				PART RIGHT ANGLE SOLID OUTPUT ASSEMBLY LAYOUT				
TREATMENT	DRWN BY BL	DESIGNED BY CN	APPROVED BY MK	SCALE 1:5	DWG NUMBER	SHEET NUMBER 4 OF 4			
	DATE 7/28/08	DATE 7/28/08	DATE	SUPERSEDES	DRAWING NUMBER	REV			
BALDOR • DODGE					452100-sld				