

3 STAGE REDUCER
 MODEL NUMBER: MAGNAGEAR 285
 OVERALL RATIO: XX.XX:1
 AGMA CLASS I RATING: XXXX HP @ XXXX RPM
 SERVICE FACTOR XX.XX

WEIGHT 2319 Lbs.

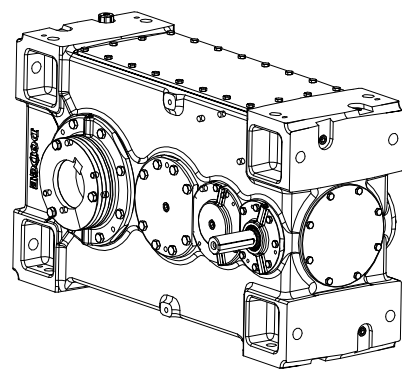

SCALE 0.094

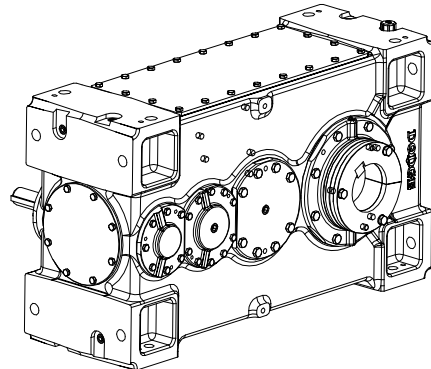

SCALE 0.094

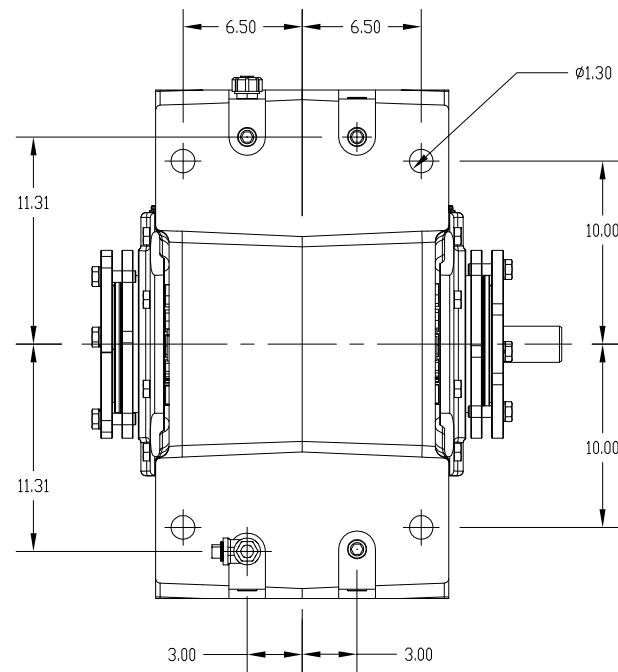

LOW SPEED
END VIEW

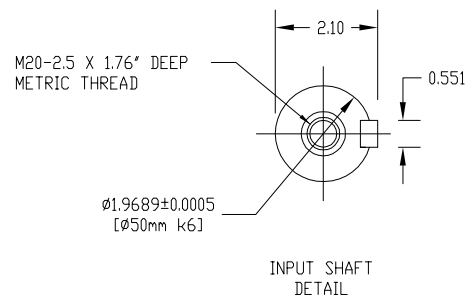
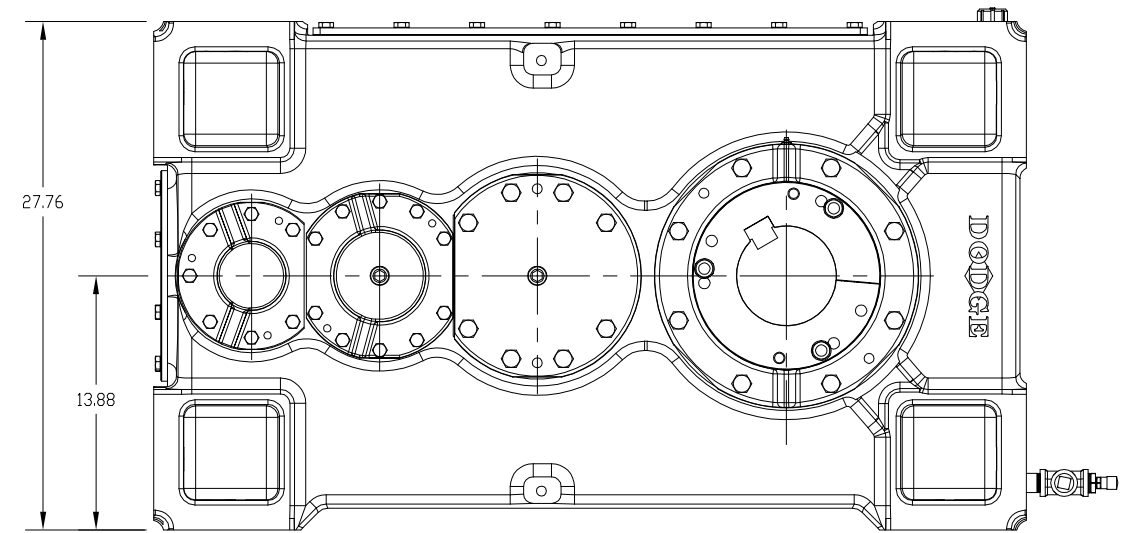
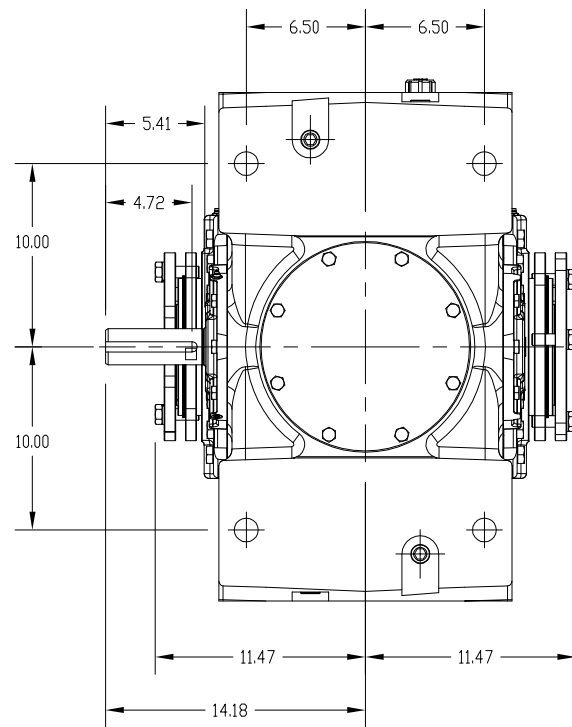
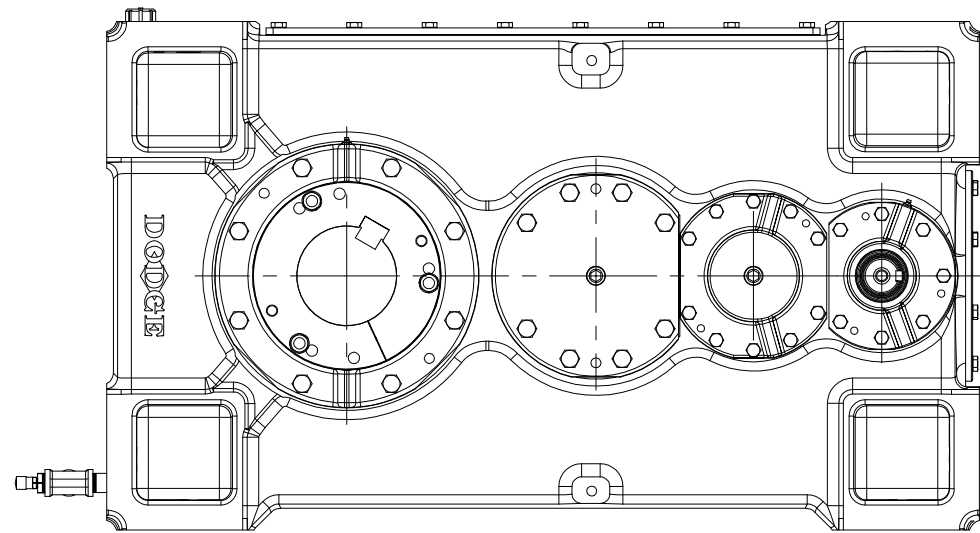
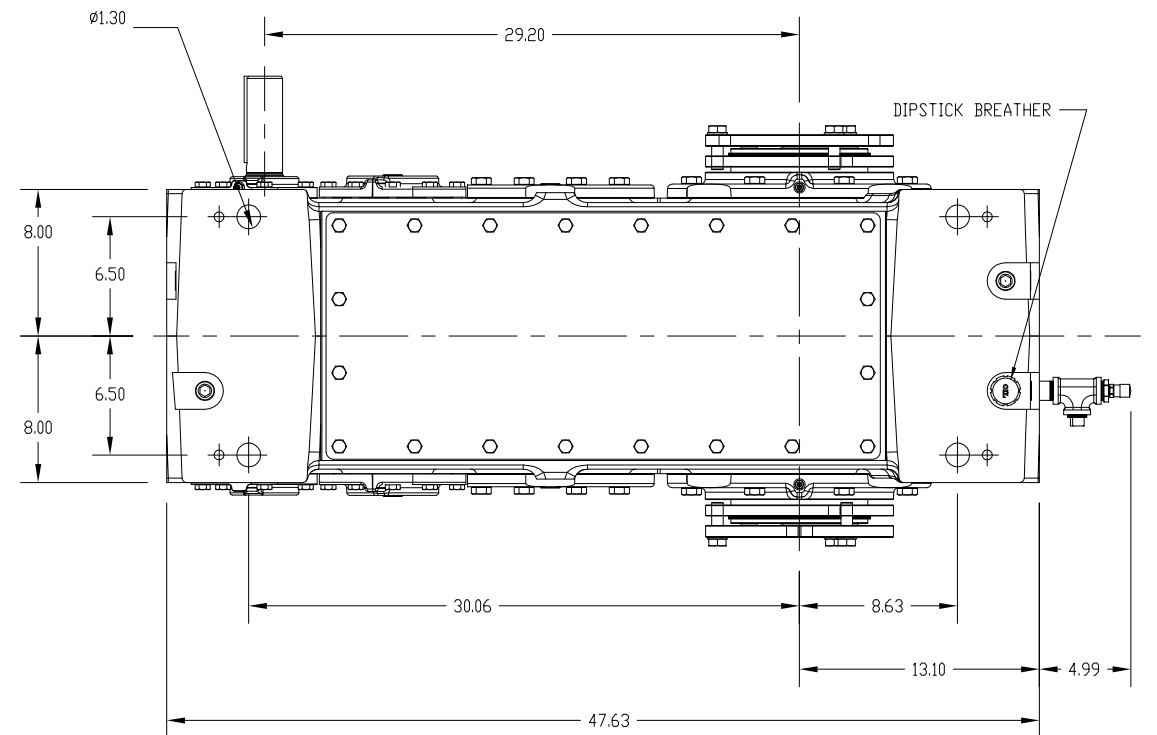

INPUT SHAFT
DETAIL

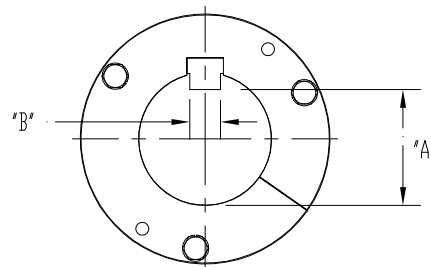

BORE DIA.	"A"	"B"
6"	5.155"	1-1/2"
5-15/16"	5.091"	1-1/2"
5-7/16"	4.740"	1-1/4"
4-15/16"	4.232"	1-1/4"
4-7/16"	3.880"	1"
4-3/16"	3.627"	1"
3-15/16"	3.373"	1"
150mm	138mm	36mm
130mm	119mm	32mm
125mm	114mm	32mm
120mm	109mm	32mm
110mm	100mm	28mm
100mm	90mm	28mm

GEOMETRIC SYMBOLS		BALDOR ELECTRIC CO. PROPRIETARY AND CONFIDENTIAL. THIS DRAWING IS THE PROPERTY OF BALDOR ELECTRIC CO. AND/OR ITS SUBSIDIARIES AND IS NOT TO BE USED, REPRODUCED OR DISCLOSED WITHOUT THE EXPRESS WRITTEN PERMISSION OF THE COMPANY.		EGR. NO.		CHK		DFT		REV		DATE		APP'D		REVISION	
FLATNESS																	
STRAIGHTNESS																	
ROUNDNESS																	
CYLINDRICITY																	
PROFILE(SURFACE)																	
PARALLELISM																	
PERPENDICULARITY																	
ANGULARITY																	
CIRCULAR RUNDUT																	
TRUE POSITION																	
CONCENTRICITY																	
TOTAL RUNDUT																	
		MATERIAL		DIMENSION TOLERANCE		UNLESS OTHERWISE SPECIFIED		PRODUCT		MAGNAGEAR 285K		DIST					
		CASTING OR FORGING NO.		MACHINE TOL. S022		CASTING TOL. S249		PART		PARALLEL INPUT HOLLOW OUTPUT							
				FABRICATING TOL. S356		BRK ALL SHRP CORNRS 0.005-0.015		TRIPLE REDUCTION ASSEMBLY LAYOUT									
		TREATMENT		DRAWN BY		ESTERLE		CHECKED BY		TALIAFERRO		APPROVED BY		KONRUFF		SCALE	
				DATE		06/05/2007		DATE				DATE				0.188	
																SHEET NUMBER	
																2 OF 4	
																DRAWING NUMBER	
																451640-HLW B	



451640-HLW B