

CUSTOMER ORDER NO.: _____
 2 STAGE REDUCER
 MODEL NUMBER: 390K
 OVERALL RATIO: _____:1
 AGMA CLASS 1 RATING: _____ @ _____ RPM
 SERVICE FACTOR: _____
 WEIGHT 2918 LBS.

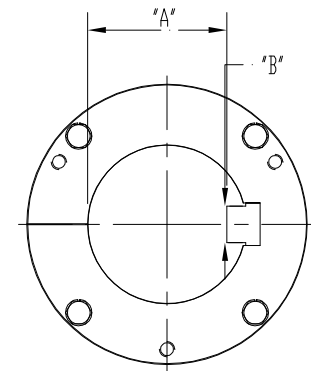
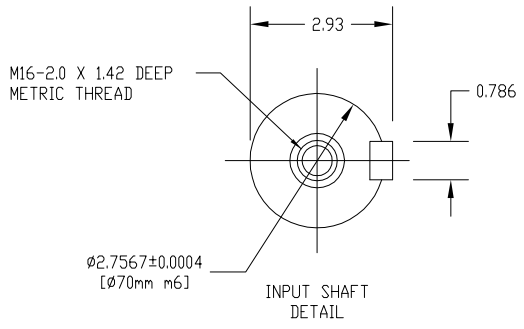
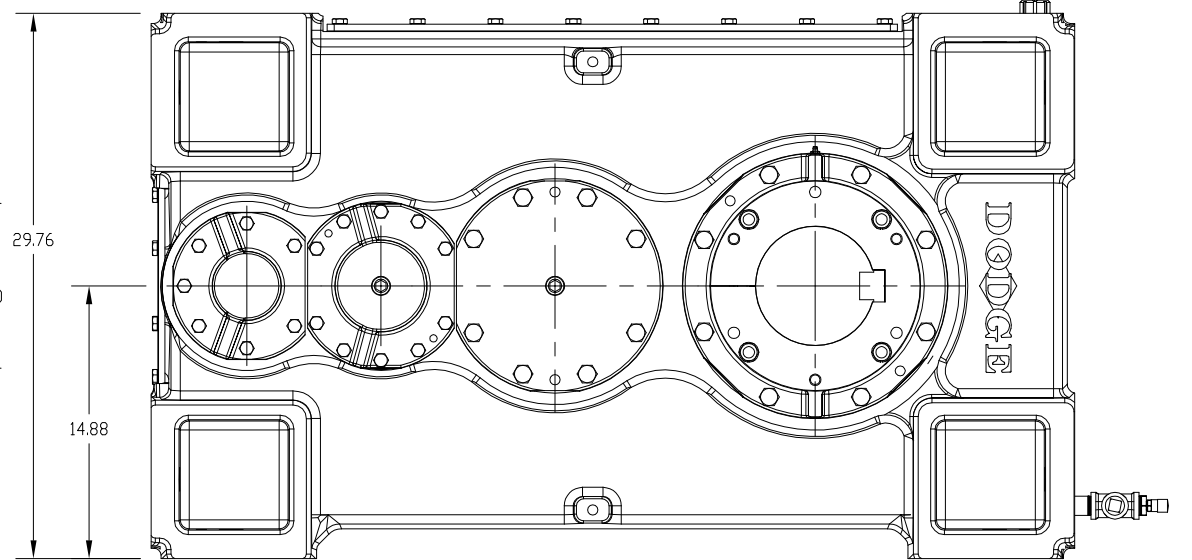
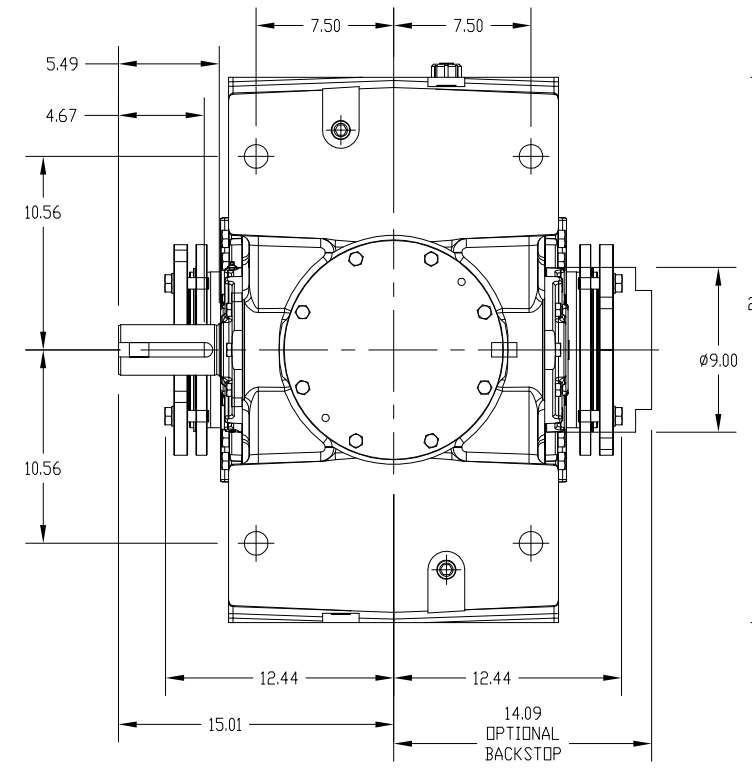
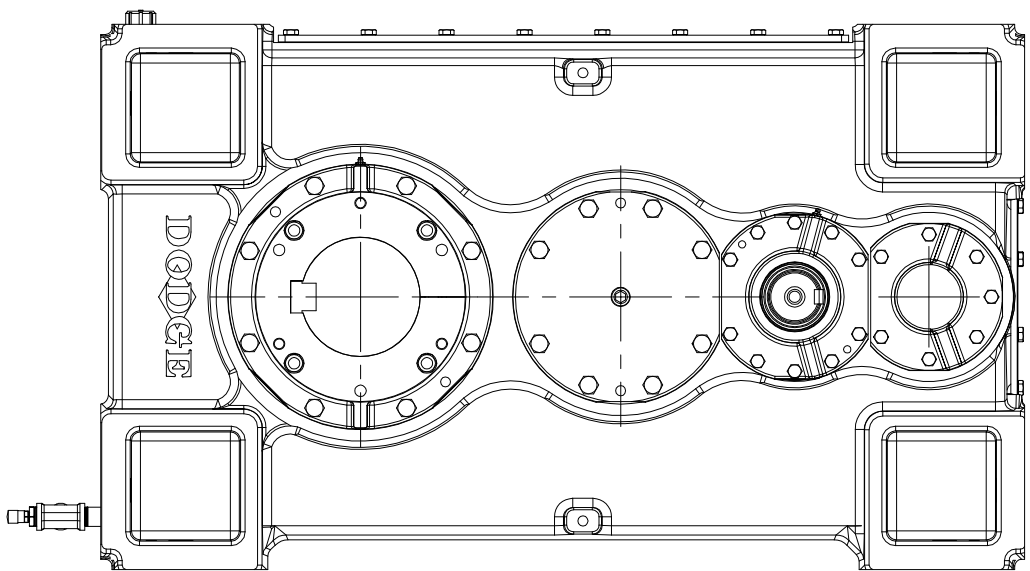
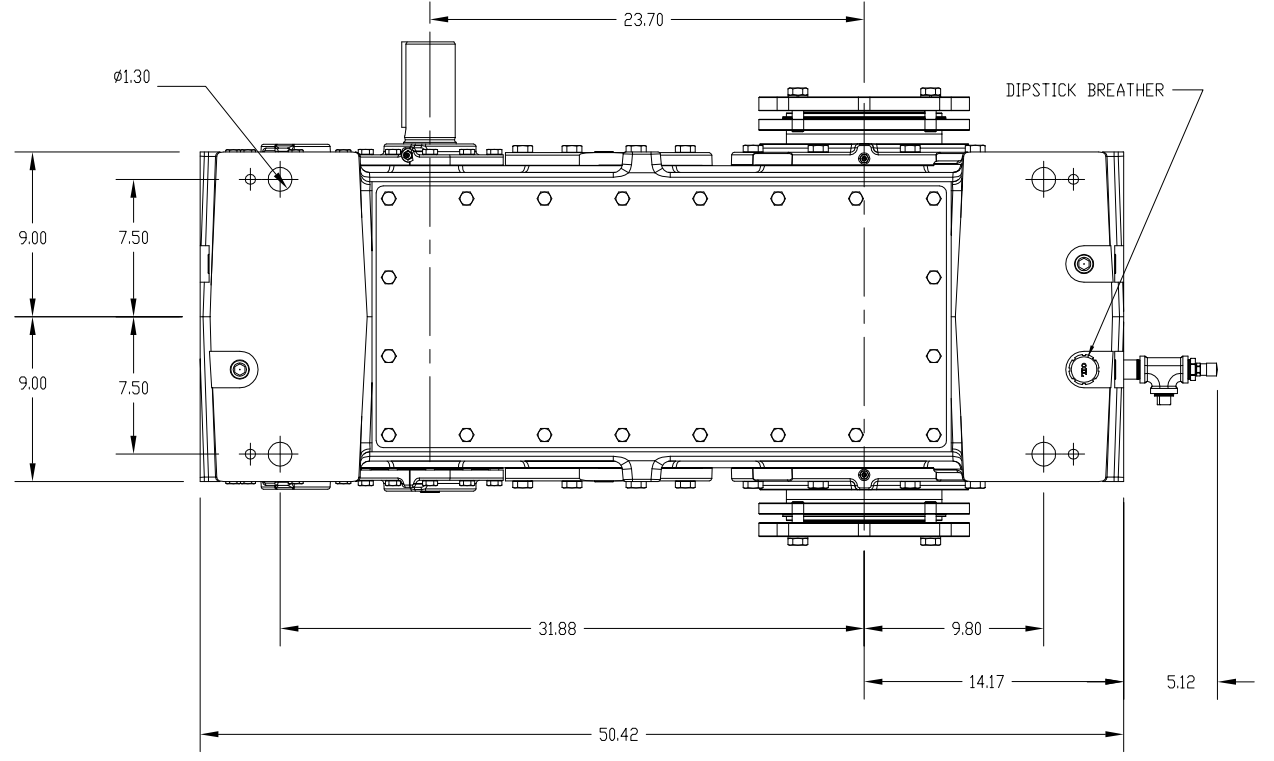
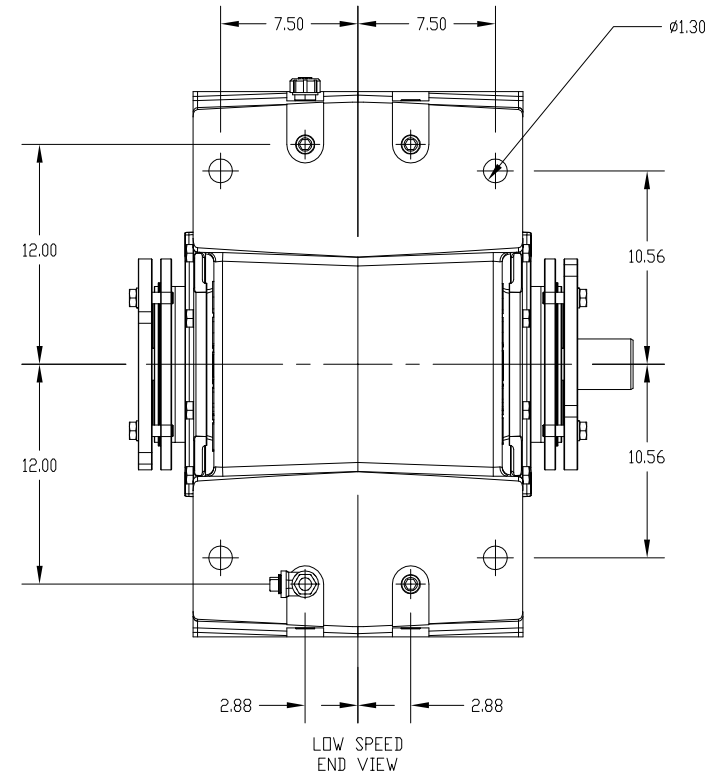
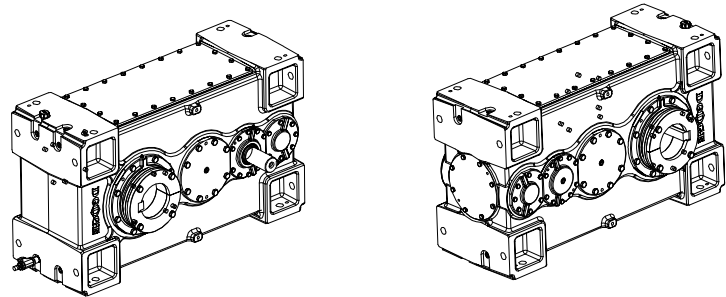

BORE DIA.	"A"	"B"
7"	6.014"	1-3/4"
6-1/2"	5.662"	1-1/2"
6-7/16"	5.599"	1-1/2"
6"	5.155"	1-1/2"
5-15/16"	5.091"	1-1/2"
5-7/16"	4.740"	1-1/4"
4-15/16"	4.232"	1-1/4"
160mm	147mm	40mm
150mm	138mm	36mm
130mm	119mm	32mm
125mm	114mm	32mm

GEOMETRIC SYMBOLS		BALDOR ELECTRIC CO. PROPRIETARY AND CONFIDENTIAL. THIS DRAWING IS THE PROPERTY OF BALDOR ELECTRIC CO. AND/OR ITS SUBSIDIARIES AND IS NOT TO BE USED, REPRODUCED OR DISCLOSED WITHOUT THE EXPRESS WRITTEN PERMISSION OF THE COMPANY.		E.C.R. NO.		CHK		DFT		REV		DATE		APP'D		REVISION	
FLATNESS				TFE	TFE	A	05/27/08	MK	ADDED BUSHING DATA								
STRAIGHTNESS																	
ROUNDNESS																	
CYLINDRICITY		MATERIAL		DIMENSION TOLERANCE		PRODUCT		MAGNAGEAR 390K		DIST							
PROFILE(SURFACE)		UNLESS OTHERWISE SPECIFIED		MACHINE TOL. S022		PART		PARALLEL INPUT HOLLOW OUTPUT		DOUBLE REDUCTION ASSEMBLY LAYOUT							
PARALLELISM		CASTING OR FORGING NO.		CASTING TOL. S249		FABRICATING TOL. S356											
PERPENDICULARITY		BRK ALL SHRP CORNRS 0.005-0.015		TREATMENT		ESTERLE		DATE		11/20/2007		SCALE		0.188		SHEET NUMBER	
ANGULARITY																	
CIRCULAR RUNOUT																	
TRUE POSITION																	
CONCENTRICITY																	
TOTAL RUNOUT																	

BALDOR • DODGE

DRAWING NUMBER
453342-HLW