

2 STAGE REDUCER
 MODEL NUMBER: 390K
 OVERALL RATIO: XX.XX:1
 AGMA CLASS 1 RATING: XXXX @ XXXX RPM
 SERVICE FACTOR: XX.XX

WEIGHT 3262 LBS..

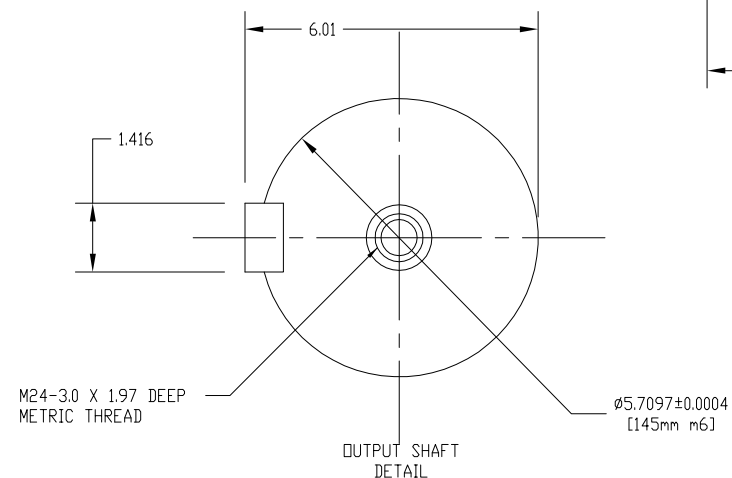
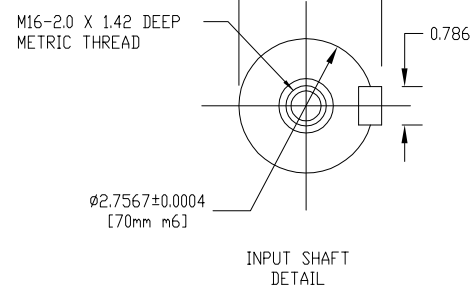
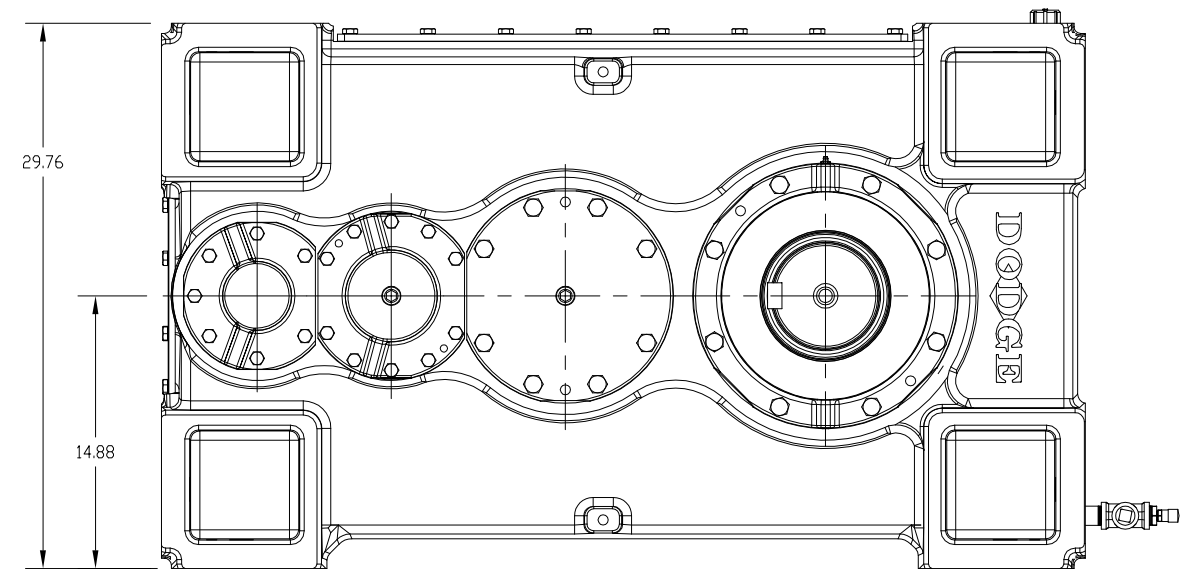
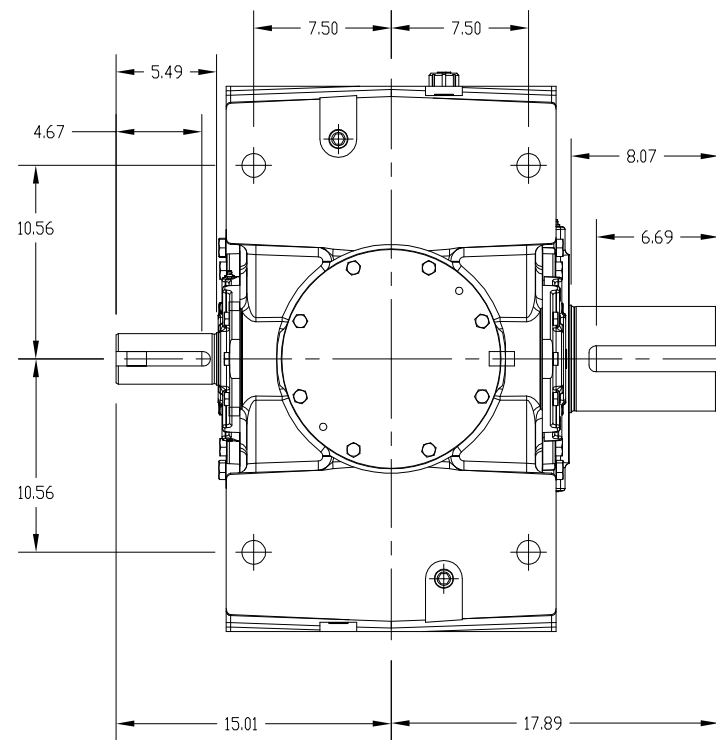
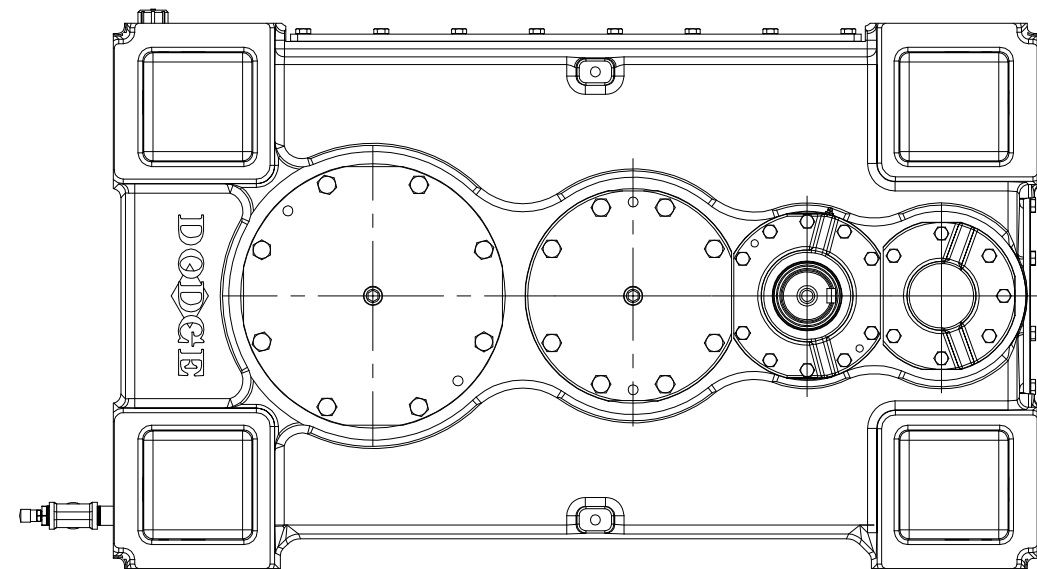
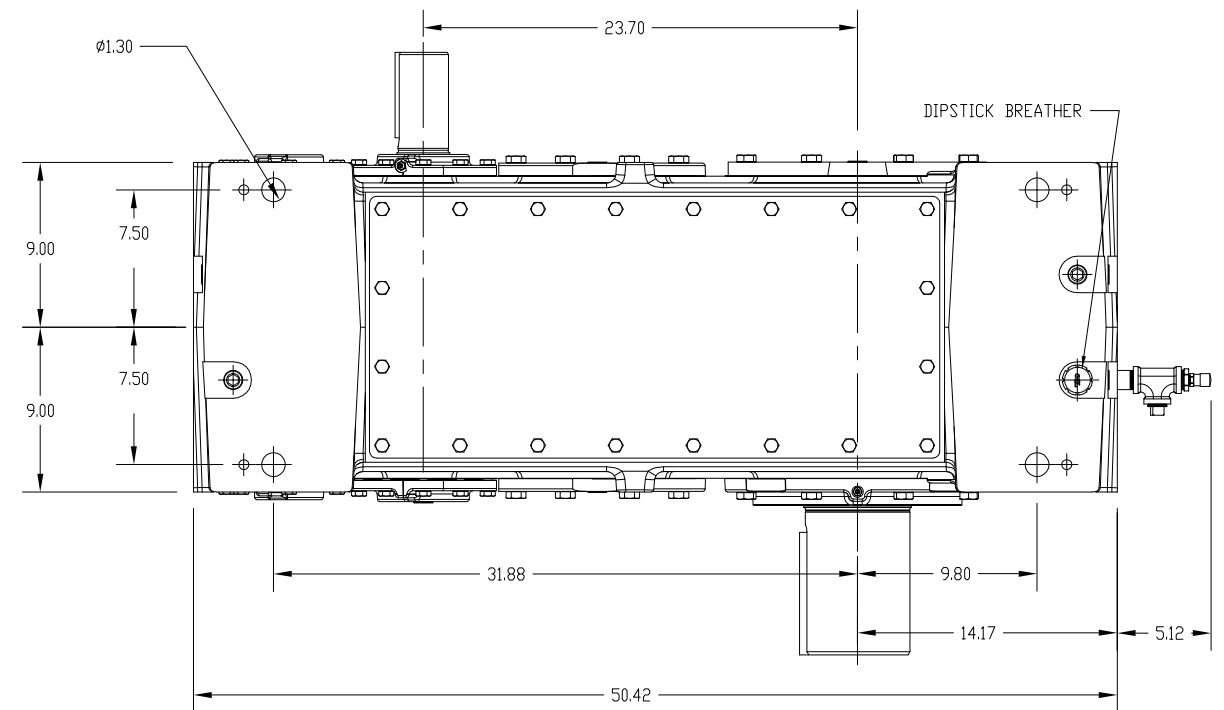
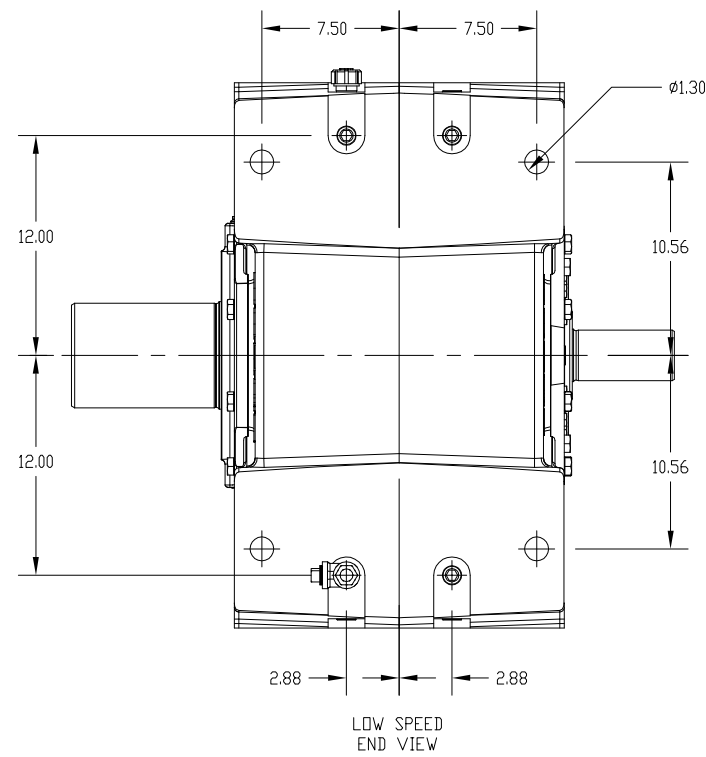
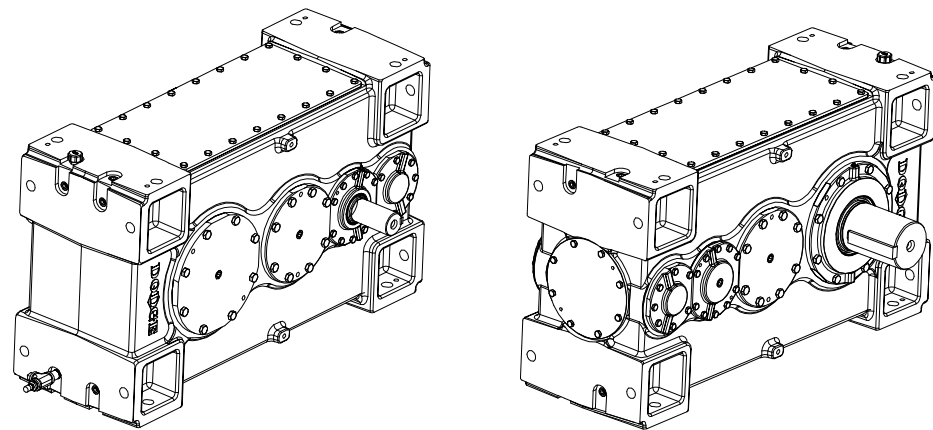

GEOMETRIC SYMBOLS		BALDOR ELECTRIC CO. PROPRIETARY AND CONFIDENTIAL. THIS DRAWING IS THE PROPERTY OF BALDOR ELECTRIC CO. AND/OR ITS SUBSIDIARIES AND IS NOT TO BE USED, REPRODUCED OR DISCLOSED WITHOUT THE EXPRESS WRITTEN PERMISSION OF THE COMPANY.		ECR. NO.		CHK	DFT	REV	DATE	APP'D	REVISION
FLATNESS		MATERIAL	DIMENSION TOLERANCE UNLESS OTHERWISE SPECIFIED	PRODUCT		MAGNAGEAR 390K		DIST			
STRAIGHTNESS		CYLINDRICITY	MACHINE TOL. S022	PART		PARALLEL INPUT SOLID OUTPUT DOUBLE REDUCTION ASSEMBLY LAYOUT					
ROUNDNESS		PROFILE(LINE)	CASTING TOL. S249	DRAWN BY		ESTERLE		SCALE		0.188	
CYLINDRICITY		PROFILE(SURFACE)	FABRICATING TOL. S356	CHECKED BY		DATE		SHEET NUMBER		4 OF 4	
PARALLELISM		PERPENDICULARITY	BRK ALL SHRP CORNRS 0.005-0.015	DATE		11/21/2007		DRAWING NUMBER		453342-SLD	
ANGULARITY		TREATMENT		DATE				SHEET NUMBER		4 OF 4	
CIRCULAR RUNDOUT				DATE				DRAWING NUMBER		453342-SLD	
TRUE POSITION				DATE				DRAWING NUMBER		453342-SLD	
CONCENTRICITY				DATE				DRAWING NUMBER		453342-SLD	
TOTAL RUNDOUT				DATE				DRAWING NUMBER		453342-SLD	