

3 STAGE REDUCER
 MODEL NUMBER: MAGNAGEAR 390K
 OVERALL RATIO: XX.XX:1
 AGMA CLASS 1 RATING: XXXX HP @ XXXX RPM
 SERVICE FACTOR XX.XX

WEIGHT: 3262 Lbs.

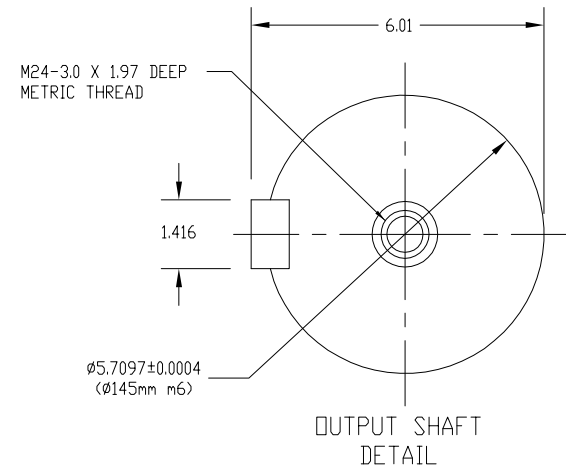
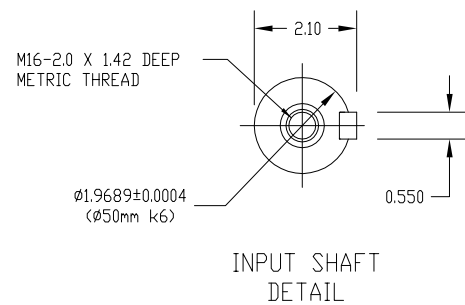
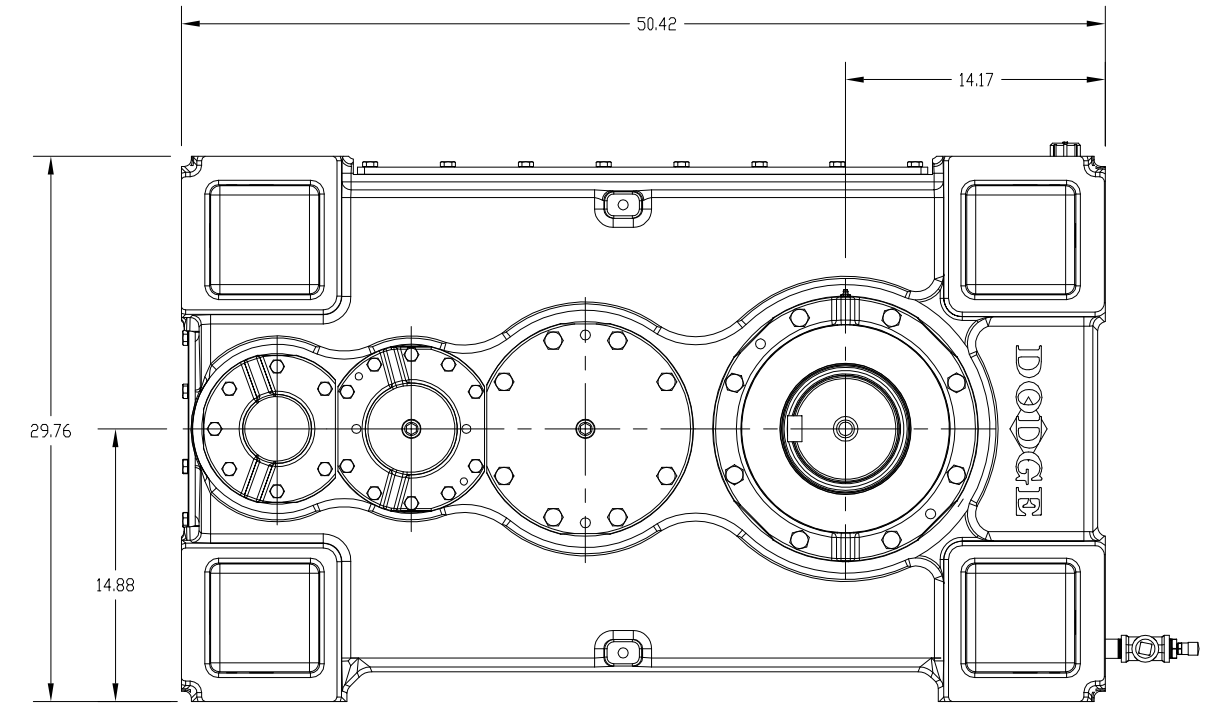
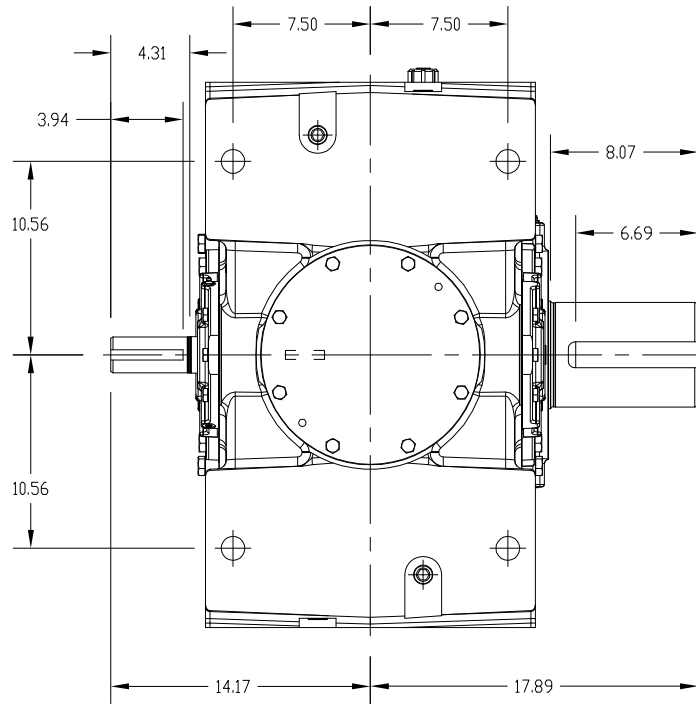
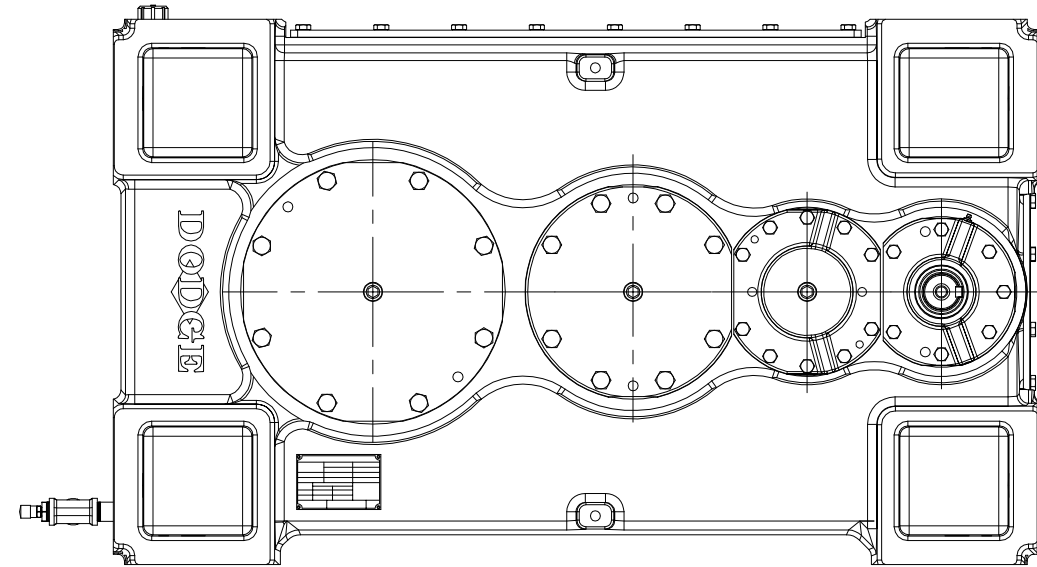
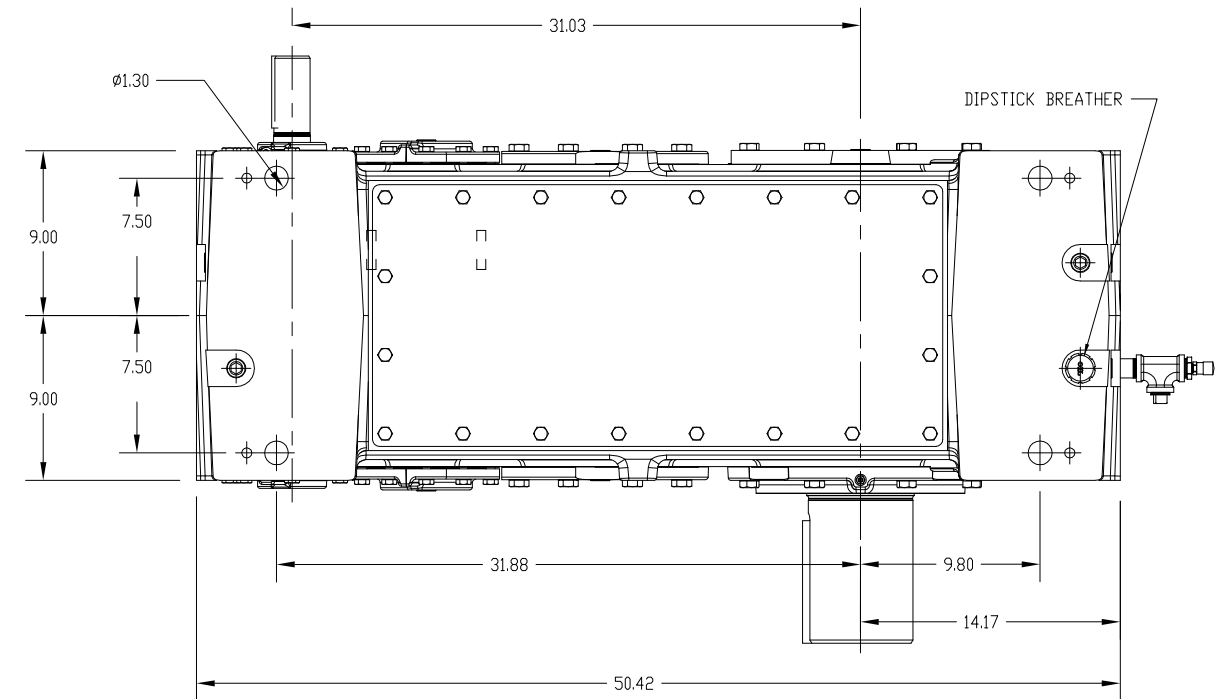
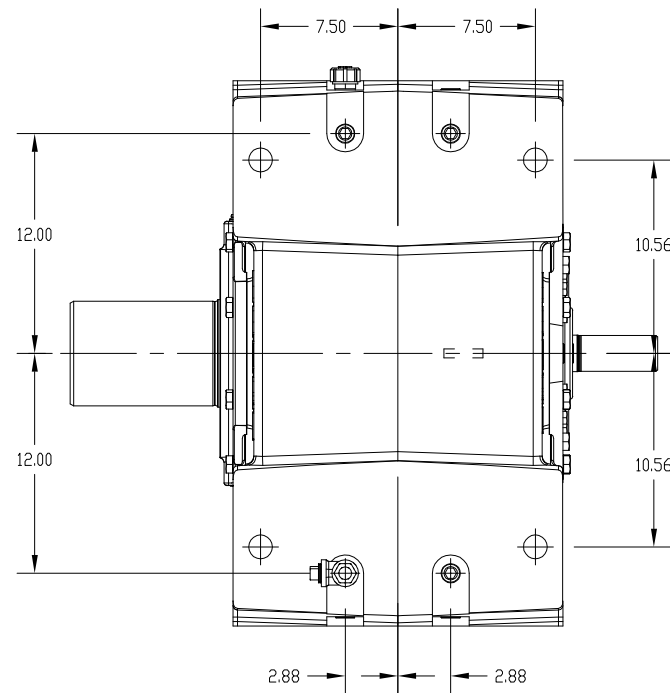
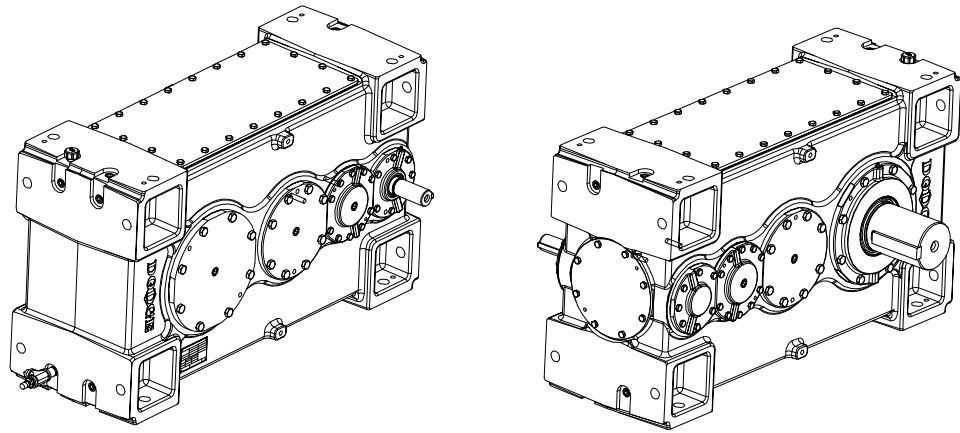

GEOMETRIC SYMBOLS		BALDOR ELECTRIC CO. PROPRIETARY AND CONFIDENTIAL. THIS DRAWING IS THE PROPERTY OF BALDOR ELECTRIC CO. AND/OR ITS SUBSIDIARIES AND IS NOT TO BE USED, DUPLICATED OR DISCLOSED WITHOUT THE EXPRESS WRITTEN PERMISSION OF THE COMPANY.		EGR. NO.		CHK	DFT	REV	DATE	APP'D	REVISION
FLATNESS		MATERIAL	DIMENSION TOLERANCE UNLESS OTHERWISE SPECIFIED	PRODUCT		MAGNAGEAR 390K		DIST			
STRAIGHTNESS		CYLINDRICITY	MACHINE TOL. S022	PART		PARALLEL INPUT SOLID OUTPUT TRIPLE REDUCTION ASSEMBLY LAYOUT		SHEET NUMBER		4 OF 4	
ROUNDNESS		PROFILE(LINE)	CASTING TOL. S249	DRAWN BY		ESTERLE		SCALE		0.188	
PARALLELISM		PERPENDICULARITY	FABRICATING TOL. S356	CHECKED BY		DATE		DATE		DATE	
CIRCULAR RUNDUT		TRUE POSITION	BRK ALL SHRP CORNRS 0.005-0.015	APPROVED BY		DATE		DATE		DATE	
CONCENTRICITY		TOTAL RUNDUT		DRAWING NUMBER		451840-SLD					