

3 STAGE REDUCER
 MODEL NUMBER: 390K
 OVERALL RATIO: XX.XX:1
 AGMA CLASS 1 RATING: XXXX HP @ XXXX RPM
 SERVICE FACTOR: XX.XX

WEIGHT = 3262 Lbs.

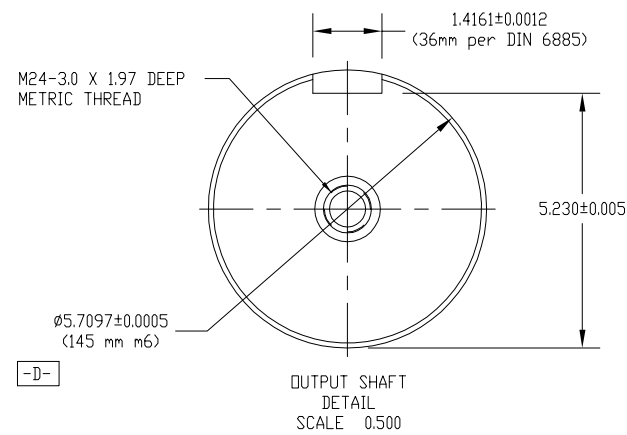
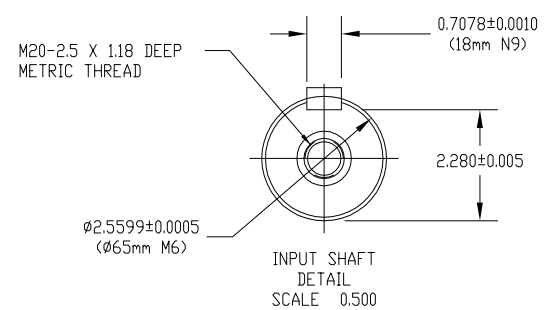
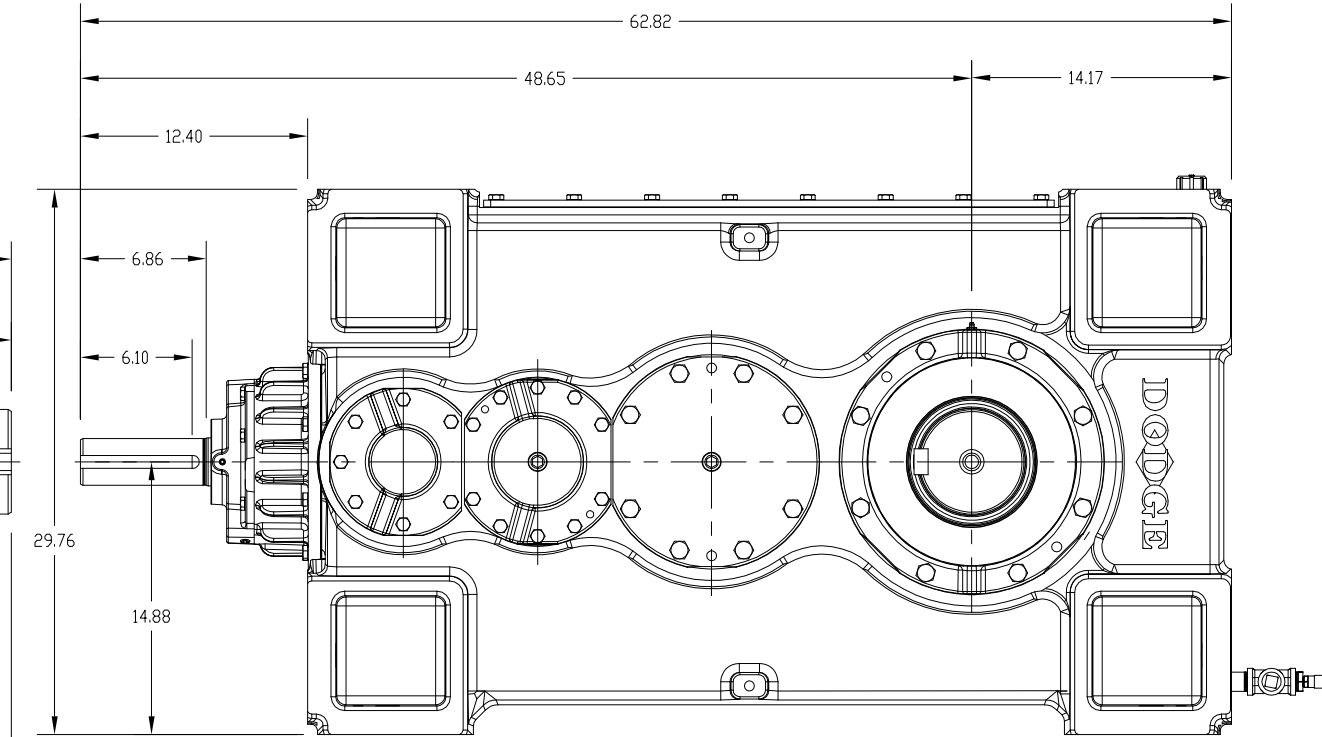
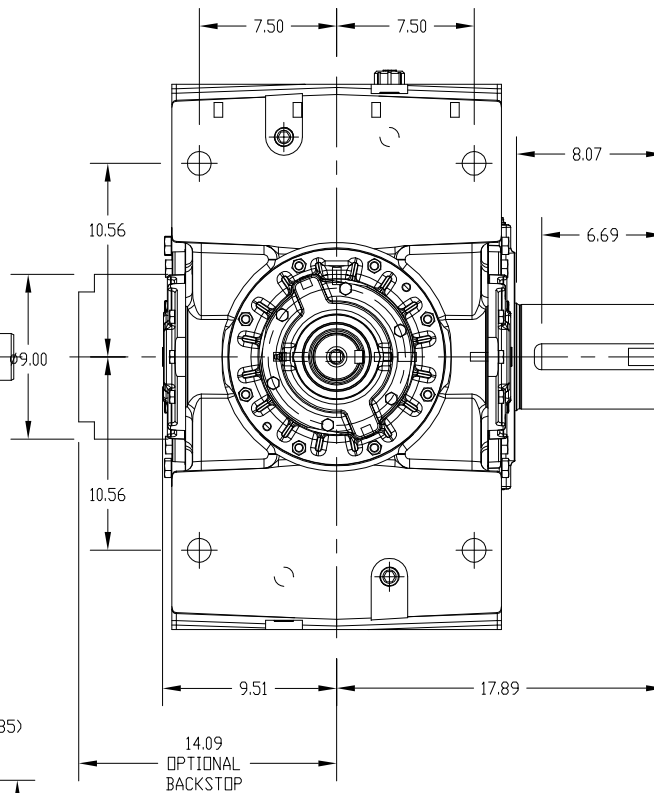
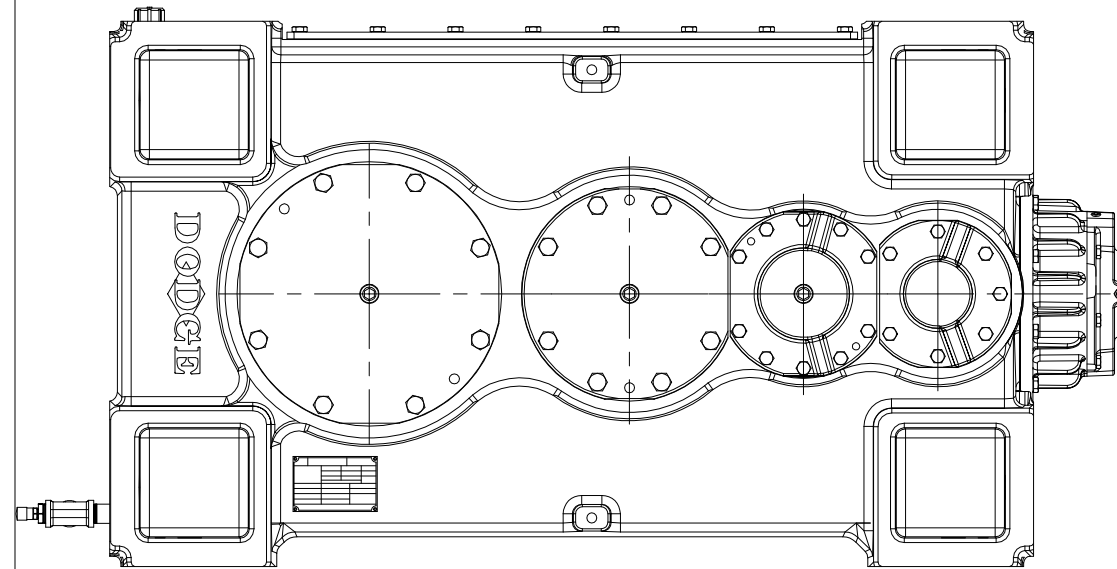
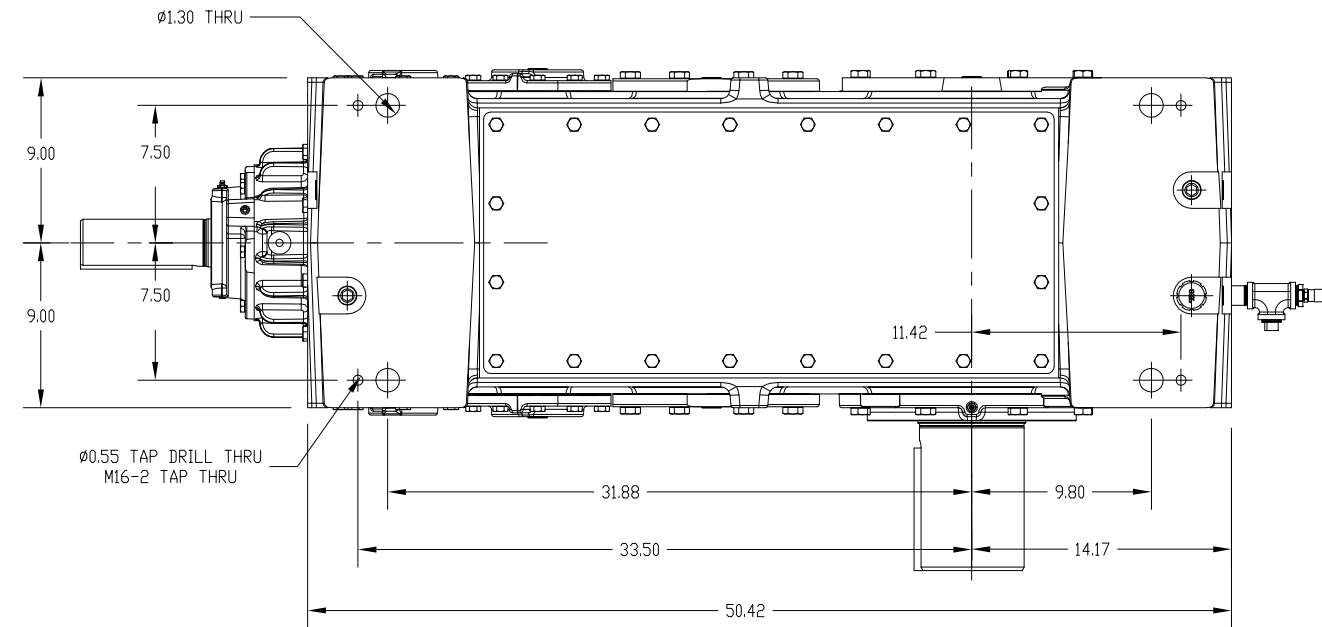
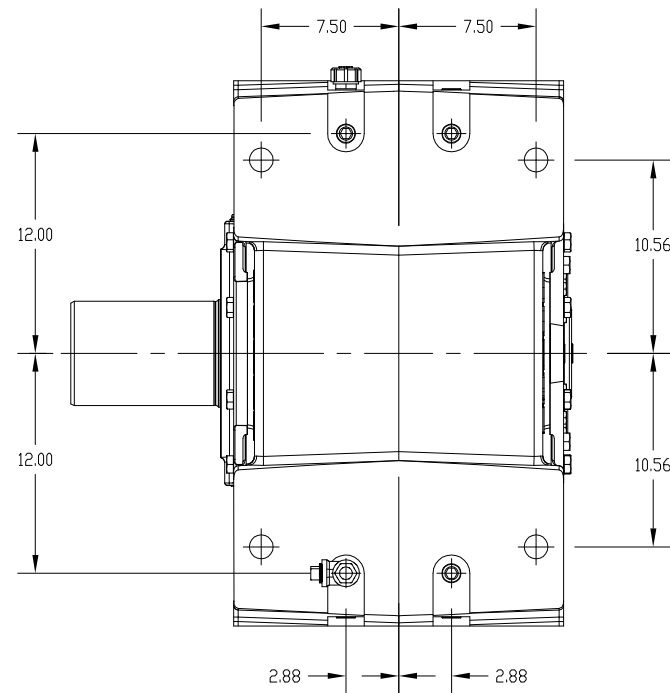
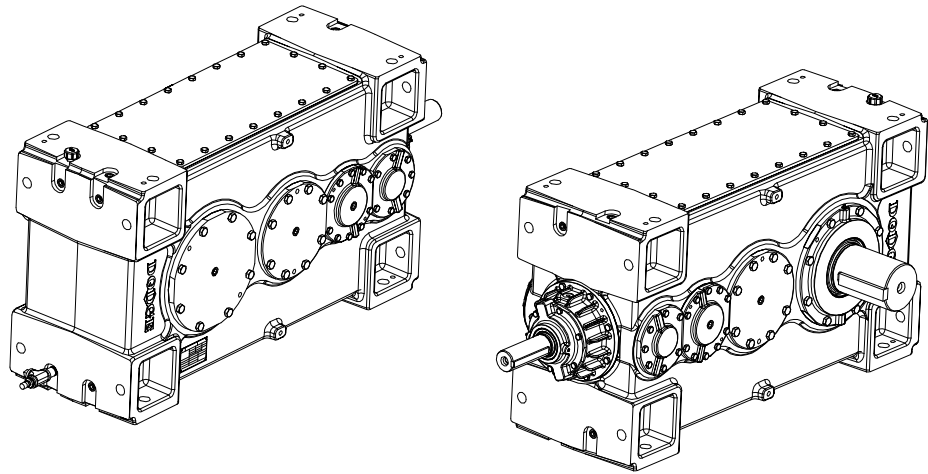

GEOMETRIC SYMBOLS		BALDOR ELECTRIC CO. PROPRIETARY AND CONFIDENTIAL. THIS DRAWING IS THE PROPERTY OF BALDOR ELECTRIC CO. AND/OR ITS SUBSIDIARIES AND IS NOT TO BE USED, REPRODUCED OR DISCLOSED WITHOUT THE EXPRESS WRITTEN PERMISSION OF THE COMPANY.		EGR. NO.		CHK		DFT		REV		DATE		APP'D		REVISION	
FLATNESS																	
STRAIGHTNESS																	
ROUNDNESS																	
CYLINDRICITY																	
PROFILE(LINE)																	
PARALLELISM																	
PERPENDICULARITY																	
ANGULARITY																	
CIRCULAR RUNDOUT																	
TRUE POSITION																	
CONCENTRICITY																	
TOTAL RUNDOUT																	

MATERIAL	DIMENSION TOLERANCE UNLESS OTHERWISE SPECIFIED	PRODUCT	MAGNAGEAR 390K	DIST	
CASTING OR FORGING NO.	MACHINE TOL. S022 CASTING TOL. S249 FABRICATING TOL. S356	PART	RIGHT ANGLE SOLID OUTPUT ASSEMBLY LAYOUT		
TREATMENT	BRK ALL SHRP CORNRS 0.005-0.015	APPROVED BY	SCALE 0.188	ORDER NUMBER	
DATE	ESTERLE	CHECKED BY	DATE	SUPERSEDES	ESTIMATE NUMBER
DATE	11/21/2007	DATE			
DRAWING NUMBER		451700-SLD			