



TORQUE-ARM Shaft Mount Speed Reducers

NOMENCLATURE: TORQUE-ARM REDUCERS

XXXX - X XX - x - X - XXXXX

Configuration

- TXT Standard TORQUE-ARM Reducer, 1 - 12
- TDT Large TORQUE-ARM Reducer, 13 - 15
- HXT HYDROIL TORQUE-ARM Reducer, 1 - 7

Gear Case Size

- 1 thru 12 TXT
- 13 thru 15 TDT
- 1 thru 7 HXT

Ratio *

- 5:1 Single Reduction
- 9, 15, 25:1 Double Reduction

Bushing Bore Size

- 1" - 10" TDT Twin Tapered Bushing Assembly
- 1" - 5-7/16" TAXD Straight Bore Bushing Assembly

Type of Reducer/Bushing

- T Twin Taper Bushed Reducer
- S Straight Bore Reducer

NOMENCLATURE EXAMPLE: TORQUE-ARM REDUCERS

TXT - 6 - 25 - T - x - 3-7/16"

- Standard TORQUE-ARM Shaft Mount Reducer _____
- Case Size 6 _____
- 25:1 Ratio, Double Reduction _____
- Twin Taper Bushed Reducer _____
- Twin Tapered Bushing Assembly with bore to fit 3-7/16" diameter driven shaft _____

TXT - 2 - 05 - S - x - 1-15/16"

- Standard TORQUE-ARM Shaft Mount Reducer _____
- Case Size 2 _____
- 5:1 Ratio, Single Reduction _____
- Straight Bore Reducer _____
- 1-15/16" is maximum bore for TXT2 Straight Bore Reducer; no bushing required _____

HXT - 1 - 25 - T - x - 1-7/16"

- HYDROIL Shaft Mount Reducer _____
- Case Size 1 _____
- 25:1 Ratio, Double Reduction _____
- Twin Taper Bushed Reducer _____
- Twin Tapered Bushing Assembly with bore to kit 1-7/16" diameter driven shaft _____

* **Note: "A" or "B" in nomenclature after ratio denotes latest reducer design**

FEATURES/BENEFITS PAGE G2- 3	EASY SELECTION PAGE G2- 13	SELECTION/DIMENSIONS PAGE G2- 28	RELATED PRODUCTS PAGE G2- 152
---------------------------------	-------------------------------	-------------------------------------	----------------------------------



NOMENCLATURE

TORQUE-ARM Shaft Mount Speed Reducers

NOMENCLATURE: SCREW CONVEYOR DRIVE REDUCERS

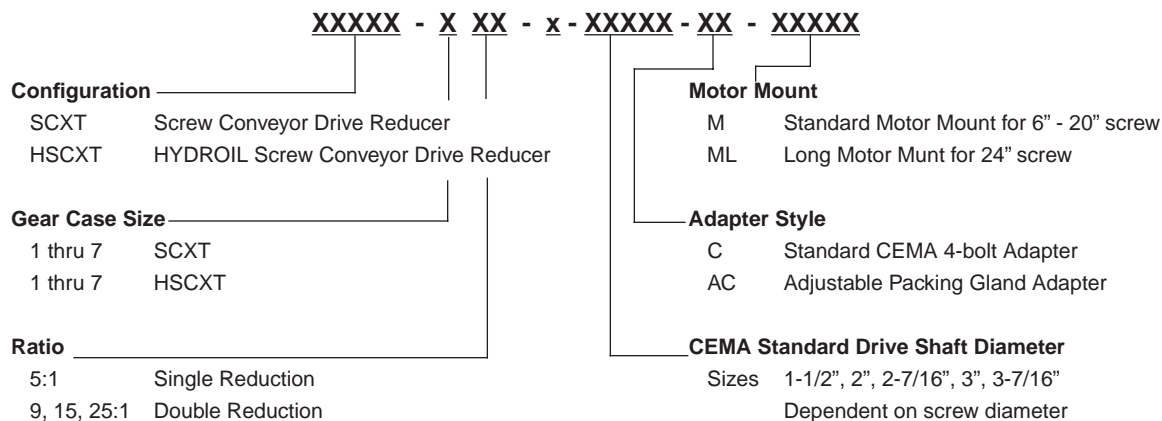

NOMENCLATURE EXAMPLE: SCREW CONVEYOR DRIVE REDUCERS

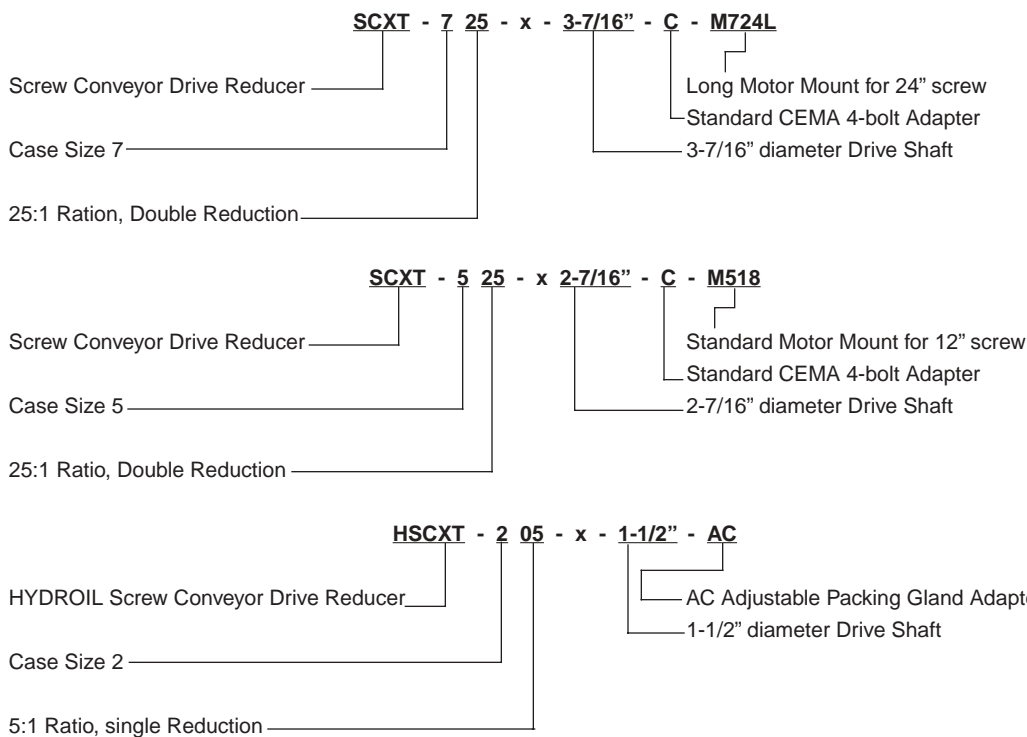

* Note: "A" or "B" in nomenclature after ratio denotes latest reducer design

FEATURES/BENEFITS PAGE G2- 3	EASY SELECTION PAGE G2- 13	SELECTION/DIMENSIONS PAGE G2- 28	RELATED PRODUCTS PAGE G2- 152
---------------------------------	-------------------------------	-------------------------------------	----------------------------------