

## SELECTION/DIMENSIONS

DODGE®



## TIGEAR-2 QUILL INPUT - SIZE 47

RATIO	OUTPUT RPM	RATING DATA 1750 INPUT RPM		PART NUMBER			SHAFT POSITION
				180TC	210TC	250TC	
5	350	Mechanical Input Hp	28.45			47Q05L25	L
		Thermal Input Hp	29.12			47Q05R25	R
		Output Torque (lb in.)	4832			47Q05LR25	LR
		Mechanical Output Hp	26.84			47Q05H25	HOLLOW
		Output OHL (lbs.)	5100				
7.5	233	Mechanical Input Hp	23.35			47Q07L25	L
		Thermal Input Hp	24.37			47Q07R25	R
		Output Torque (lb in.)	5801			47Q07LR25	LR
		Mechanical Output Hp	21.77			47Q07H25	HOLLOW
		Output OHL (lbs.)	5600				
10	175	Mechanical Input Hp	19.27		47Q10L21	47Q10L25	L
		Thermal Input Hp	20.08		47Q10R21	47Q10R25	R
		Output Torque (lb in.)	6390		47Q10LR21	47Q10LR25	LR
		Mechanical Output Hp	17.74		47Q10H21	47Q10H25	HOLLOW
		Output OHL (lbs.)	5600				
15	117	Mechanical Input Hp	14.05		47Q15L21		L
		Thermal Input Hp	14.14		47Q15R21		R
		Output Torque (lb in.)	6739		47Q15LR21		LR
		Mechanical Output Hp	12.47		47Q15H21		HOLLOW
		Output OHL (lbs.)	5600				
20	88	Mechanical Input Hp	10.82		47Q20L21		L
		Thermal Input Hp	10.96		47Q20R21		R
		Output Torque (lb in.)	6659		47Q20LR21		LR
		Mechanical Output Hp	9.24		47Q20H21		HOLLOW
		Output OHL (lbs.)	5600				
25	70	Mechanical Input Hp	8.76	47Q25L18	47Q25L21		L
		Thermal Input Hp	8.09	47Q25R18	47Q25R21		R
		Output Torque (lb in.)	6410	47Q25LR18	47Q25LR21		LR
		Mechanical Output Hp	7.12	47Q25H18	47Q25H21		HOLLOW
		Output OHL (lbs.)	5600				
30	58	Mechanical Input Hp	7.95	47Q30L18			L
		Thermal Input Hp	7.22	47Q30R18			R
		Output Torque (lb in.)	6845	47Q30LR18			LR
		Mechanical Output Hp	6.34	47Q30H18			HOLLOW
		Output OHL (lbs.)	5600				
40	44	Mechanical Input Hp	6.21	47Q40L18			L
		Thermal Input Hp	5.66	47Q40R18			R
		Output Torque (lb in.)	6644	47Q40LR18			LR
		Mechanical Output Hp	4.61	47Q40H18			HOLLOW
		Output OHL (lbs.)	5600				
50	35	Mechanical Input Hp	5.05	47Q50L18			L
		Thermal Input Hp	4.42	47Q50R18			R
		Output Torque (lb in.)	6241	47Q50LR18			LR
		Mechanical Output Hp	3.47	47Q50H18			HOLLOW
		Output OHL (lbs.)	5600				
60	29	Mechanical Input Hp	4.12	47Q60L18			L
		Thermal Input Hp	3.65	47Q60R18			R
		Output Torque (lb in.)	5683	47Q60LR18			LR
		Mechanical Output Hp	2.63	47Q60H18			HOLLOW
		Output OHL (lbs.)	5600				

**Note:** Reducers are shipped without a mounting base. Order bolt-on base kit **47BASE** if required.

# SELECTION/DIMENSIONS



## TIGEAR-2 QUILL INPUT - SIZE 47

### SOLID OUTPUT

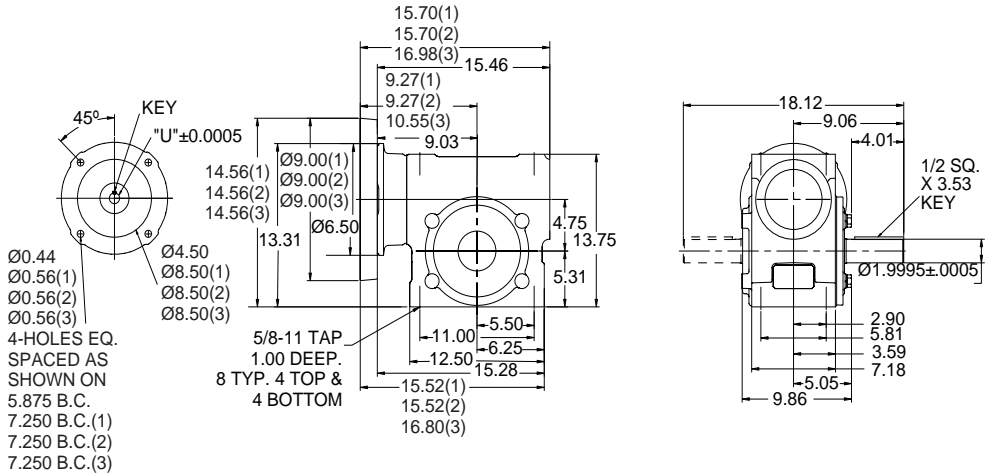

- (1) DIMENSIONS APPLY TO 180 FRAME MOTOR ADAPTER  
 (2) DIMENSIONS APPLY TO 210 FRAME MOTOR ADAPTER  
 (3) DIMENSIONS APPLY TO 250 FRAME MOTOR ADAPTER

### HOLLOW OUTPUT

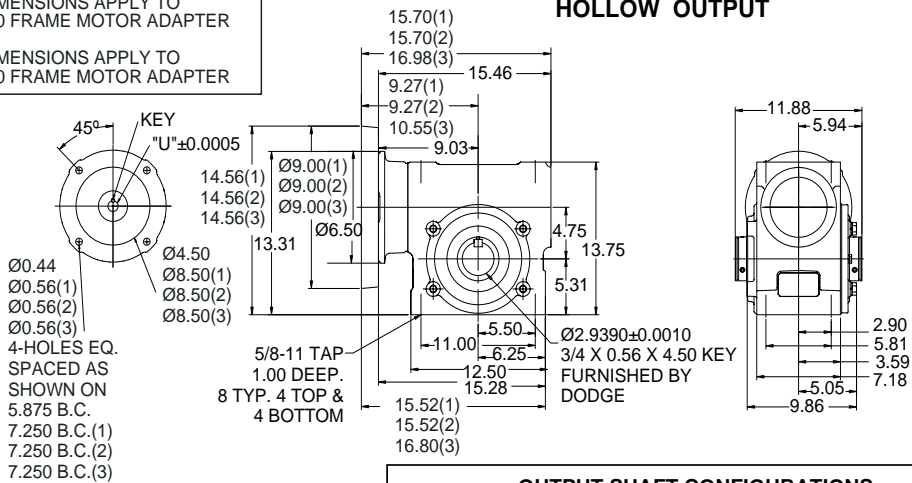

### OUTPUT SHAFT CONFIGURATIONS

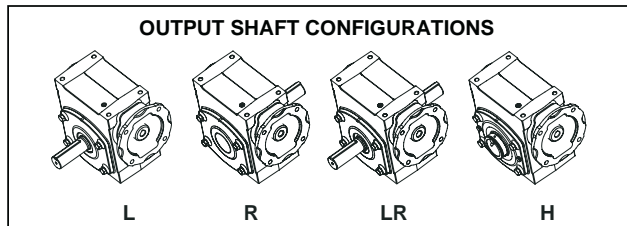

MOTOR FRAME	DIM "U"	KEY
140TC 160ATC	$\varnothing 0.876$	3/16 SQ X 2.75 KEY
180TC 180ATC	$\varnothing 1.126$	1/4 SQ. X 2.98 KEY
210TC 210ATC	$\varnothing 1.376$	5/16 SQ X 3.11 KEY
250TC 250ATC	$\varnothing 1.626$	3/8 SQ X 3.38 KEY

## SELECTION/DIMENSIONS



## TIGEAR-2 SEPARATE INPUT - SIZE 47

RATIO	OUTPUT RPM	RATING DATA 1750 INPUT RPM		SEPARATE REDUCER	SHAFT POSITION	OPTIONAL MOTOR ADAPTER KIT		
						180TC	210TC	250TC
5	350	Mechanical Input Hp	28.45	47S05L	L	4047MTR21	4047MTR25	
		Thermal Input Hp	29.12	47S05R	R			
		Output Torque (lb in.)	4832	47S05LR	LR			
		Mechanical Output Hp	26.84	47S05H	HOLLOW			
		Output OHL (lbs.)	5100					
7.5	233	Mechanical Input Hp	23.35	47S07L	L	4047MTR21	4047MTR25	
		Thermal Input Hp	24.37	47S07R	R			
		Output Torque (lb in.)	5801	47S07LR	LR			
		Mechanical Output Hp	21.77	47S07H	HOLLOW			
		Output OHL (lbs.)	5600					
10	175	Mechanical Input Hp	19.27	47S10L	L	4047MTR21		
		Thermal Input Hp	20.08	47S10R	R			
		Output Torque (lb in.)	6390	47S10LR	LR			
		Mechanical Output Hp	17.74	47S10H	HOLLOW			
		Output OHL (lbs.)	5600					
15	117	Mechanical Input Hp	14.05	47S15L	L	4047MTR18	4047MTR21	
		Thermal Input Hp	14.14	47S15R	R			
		Output Torque (lb in.)	6739	47S15LR	LR			
		Mechanical Output Hp	12.47	47S15H	HOLLOW			
		Output OHL (lbs.)	5600					
20	88	Mechanical Input Hp	10.82	47S20L	L	4047MTR18	4047MTR21	
		Thermal Input Hp	10.96	47S20R	R			
		Output Torque (lb in.)	6659	47S20LR	LR			
		Mechanical Output Hp	9.24	47S20H	HOLLOW			
		Output OHL (lbs.)	5600					
25	70	Mechanical Input Hp	8.76	47S25L	L	4047MTR18		
		Thermal Input Hp	8.09	47S25R	R			
		Output Torque (lb in.)	6410	47S25LR	LR			
		Mechanical Output Hp	7.12	47S25H	HOLLOW			
		Output OHL (lbs.)	5600					
30	58	Mechanical Input Hp	7.95	47S30L	L	4047MTR18		
		Thermal Input Hp	7.22	47S30R	R			
		Output Torque (lb in.)	6845	47S30LR	LR			
		Mechanical Output Hp	6.34	47S30H	HOLLOW			
		Output OHL (lbs.)	5600					
40	44	Mechanical Input Hp	6.21	47S40L	L	4047MTR18		
		Thermal Input Hp	5.66	47S40R	R			
		Output Torque (lb in.)	6644	47S40LR	LR			
		Mechanical Output Hp	4.61	47S40H	HOLLOW			
		Output OHL (lbs.)	5600					
50	35	Mechanical Input Hp	5.05	47S50L	L	4047MTR18		
		Thermal Input Hp	4.42	47S50R	R			
		Output Torque (lb in.)	6241	47S50LR	LR			
		Mechanical Output Hp	3.47	47S50H	HOLLOW			
		Output OHL (lbs.)	5600					
60	29	Mechanical Input Hp	4.12	47S60L	L			
		Thermal Input Hp	3.65	47S60R	R			
		Output Torque (lb in.)	5683	47S60LR	LR			
		Mechanical Output Hp	2.63	47S60H	HOLLOW			
		Output OHL (lbs.)	5600					
All Ratios		Input OHL (lbs)	500	One diameter from seal surface				

**Note:** TIGEAR-2 separate reducers cannot be used with the old Adaptable TIGEAR motor adapter kits.

# SELECTION/DIMENSIONS



## TIGEAR-2 SEPARATE INPUT - SIZE 47

### SOLID OUTPUT

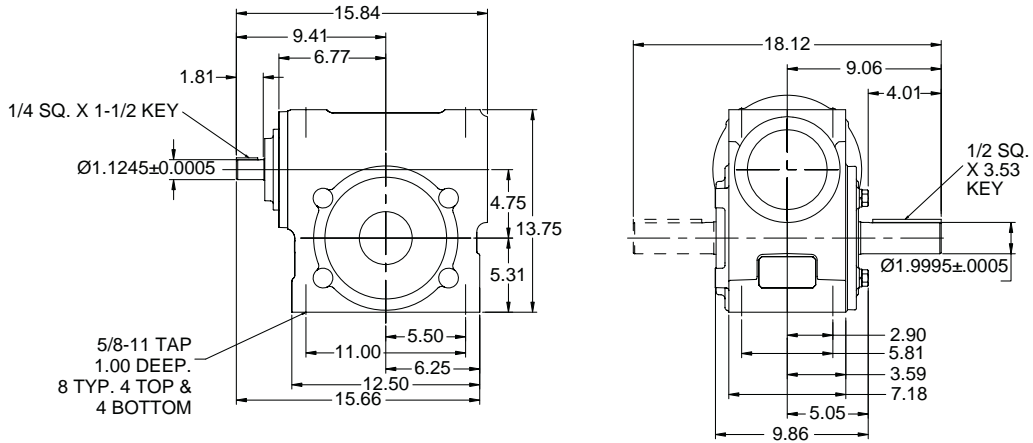

### HOLLOW OUTPUT

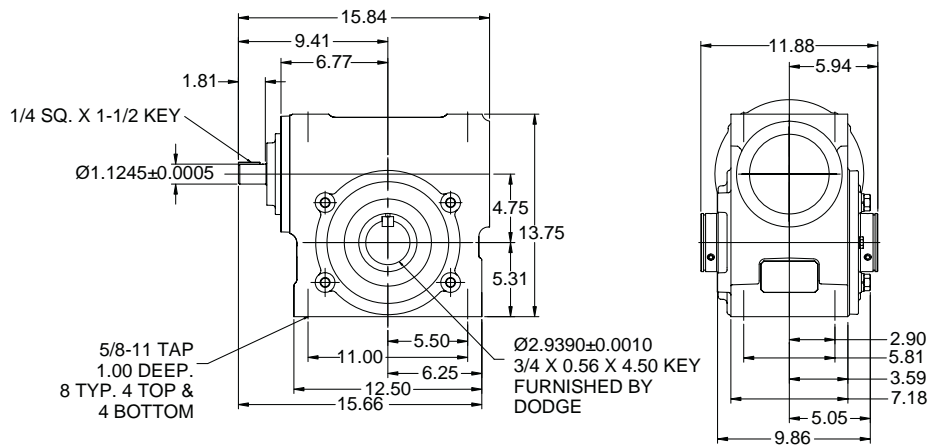

### OUTPUT SHAFT CONFIGURATIONS

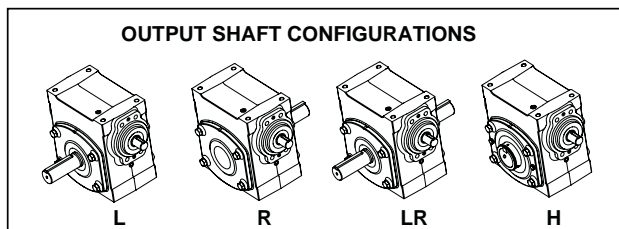



# SELECTION/DIMENSIONS

## TIGEAR-2 COUPLED INPUT - ADAPTER ASSEMBLY - SIZE 47

Coupled input units include a Separate reducer and motor adapter kit assembled together.

These assemblies are normally "made to order" with a 5 day standard lead time.

RATIO	OUTPUT RPM	RATING DATA 1750 INPUT RPM		PART NUMBER			SHAFT POSITION
				180TC	210TC	250TC	
5	350	Mechanical Input Hp	28.45			47A05L25	L
		Thermal Input Hp	29.12			47A05R25	R
		Output Torque (lb in.)	4832			47A05LR25	LR
		Mechanical Output Hp	26.84			47A05H25	HOLLOW
		Output OHL (lbs.)	5100				
7.5	233	Mechanical Input Hp	23.35			47A07L25	L
		Thermal Input Hp	24.37			47A07R25	R
		Output Torque (lb in.)	5801			47A07LR25	LR
		Mechanical Output Hp	21.77			47A07H25	HOLLOW
		Output OHL (lbs.)	5600				
10	175	Mechanical Input Hp	19.27		47A10L21	47A10L25	L
		Thermal Input Hp	20.08		47A10R21	47A10R25	R
		Output Torque (lb in.)	6390		47A10LR21	47A10LR25	LR
		Mechanical Output Hp	17.74		47A10H21	47A10H25	HOLLOW
		Output OHL (lbs.)	5600				
15	117	Mechanical Input Hp	14.05		47A15L21		L
		Thermal Input Hp	14.14		47A15R21		R
		Output Torque (lb in.)	6739		47A15LR21		LR
		Mechanical Output Hp	12.47		47A15H21		HOLLOW
		Output OHL (lbs.)	5600				
20	88	Mechanical Input Hp	10.82		47A20L21		L
		Thermal Input Hp	10.96		47A20R21		R
		Output Torque (lb in.)	6659		47A20LR21		LR
		Mechanical Output Hp	9.24		47A20H21		HOLLOW
		Output OHL (lbs.)	5600				
25	70	Mechanical Input Hp	8.76	47A25L18	47A25L21		L
		Thermal Input Hp	8.09	47A25R18	47A25R21		R
		Output Torque (lb in.)	6410	47A25LR18	47A25LR21		LR
		Mechanical Output Hp	7.12	47A25H18	47A25H21		HOLLOW
		Output OHL (lbs.)	5600				
30	58	Mechanical Input Hp	7.95	47A30L18			L
		Thermal Input Hp	7.22	47A30R18			R
		Output Torque (lb in.)	6845	47A30LR18			LR
		Mechanical Output Hp	6.34	47A30H18			HOLLOW
		Output OHL (lbs.)	5600				
40	44	Mechanical Input Hp	6.21	47A40L18			L
		Thermal Input Hp	5.66	47A40R18			R
		Output Torque (lb in.)	6644	47A40LR18			LR
		Mechanical Output Hp	4.61	47A40H18			HOLLOW
		Output OHL (lbs.)	5600				
50	35	Mechanical Input Hp	5.05	47A50L18			L
		Thermal Input Hp	4.42	47A50R18			R
		Output Torque (lb in.)	6241	47A50LR18			LR
		Mechanical Output Hp	3.47	47A50H18			HOLLOW
		Output OHL (lbs.)	5600				
60	29	Mechanical Input Hp	4.12	47A60L18			L
		Thermal Input Hp	3.65	47A60R18			R
		Output Torque (lb in.)	5683	47A60LR18			LR
		Mechanical Output Hp	2.63	47A60H18			HOLLOW
		Output OHL (lbs.)	5600				

Note: Reducers are shipped without a mounting base. Order bolt-on base kit **47BASE** if required.

FEATURES/BENEFITS PAGE G4-2	SPECIFICATION PAGE G4-8	NOMENCLATURE PAGE G4-9	MODIFICATION/ACCESSORIES PAGE G4-90
--------------------------------	----------------------------	---------------------------	----------------------------------------

# SELECTION/DIMENSIONS



## TIGEAR-2 COUPLED INPUT - ADAPTER ASSEMBLY - SIZE 47

### SOLID OUTPUT

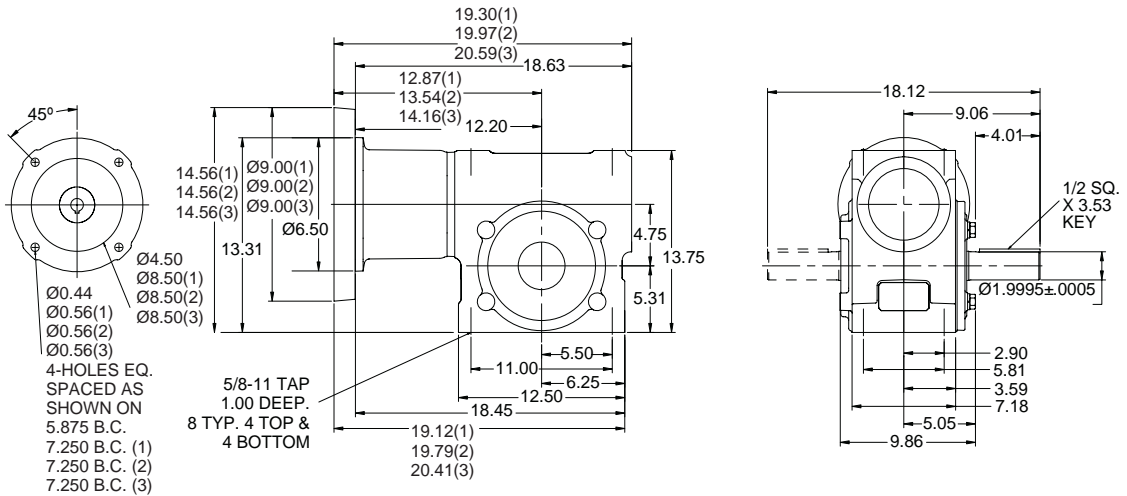

### HOLLOW OUTPUT

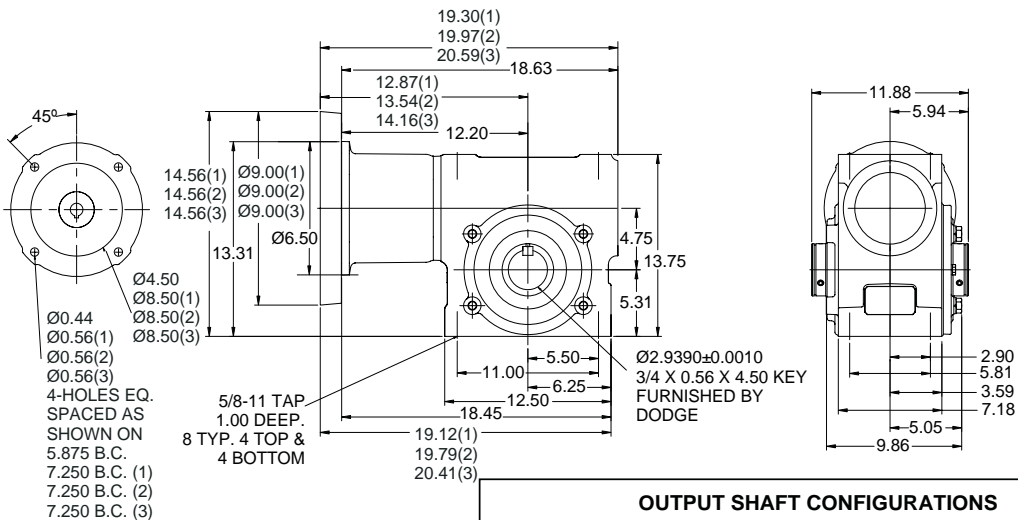

- (1) DIMENSIONS APPLY TO 180 FRAME MOTOR ADAPTER
- (2) DIMENSIONS APPLY TO 210 FRAME MOTOR ADAPTER
- (3) DIMENSIONS APPLY TO 250 FRAME MOTOR ADAPTER

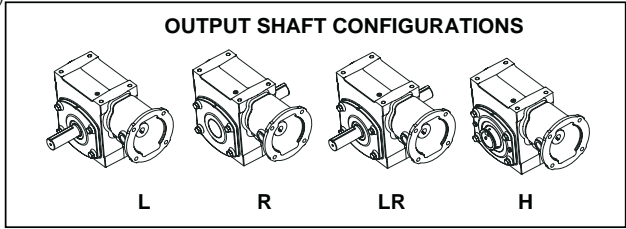

FEATURES/BENEFITS PAGE G4-2	SPECIFICATION PAGE G4-8	NOMENCLATURE PAGE G4-9	MODIFICATION/ACCESSORIES PAGE G4-90
--------------------------------	----------------------------	---------------------------	----------------------------------------