

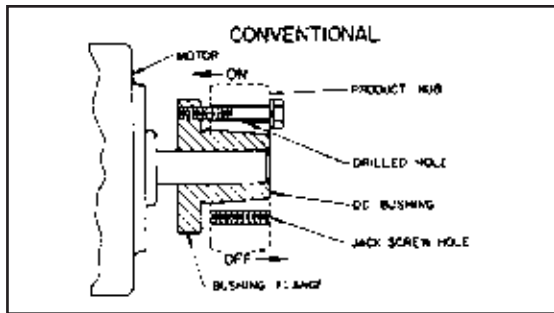

QD Bushings



- Flanged Design
- 4 Degree Taper
- Easy on/Easy off
- Manufactured precisely to industry standards
- Conventional or Reverse Mounting, Including sizes M thru S - DODGE exclusive!



Conventional Mounting

Easy On

- Place bushing in product
- Align clearance holes in product with threaded holes in bushing
- Install screws and lockwashers thru clearance holes, finger tight
- Slide assembly onto shaft, flange first
- Locate assembly on shaft for proper drive alignment
- Tighten cap screws alternately and evenly to specified torque

Easy Off

- Remove cap screws and install in product threaded holes
- Alternately and evenly tighten screws until bushing grip is released

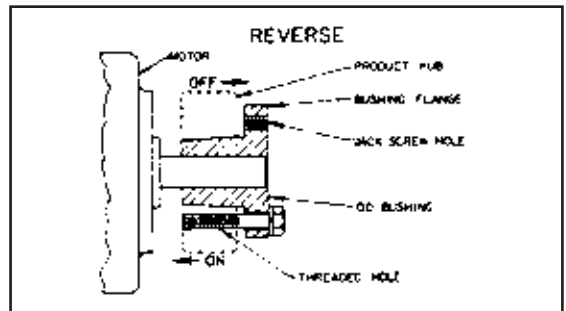

Reverse Mounting

Easy On

- Place bushing in product
- Align clearance holes in product with threaded holes in bushing
- Install screws and lockwashers thru clearance holes, finger tight
- Slide assembly onto shaft, flange outward
- Locate assembly on shaft for proper drive alignment
- Tighten cap screws alternately and evenly to specified torque

Easy Off

- Remove cap screws and reinstall in flange threaded holes
- Alternately and evenly tighten screws until bushing grip is released

IMPORTANT! Do not use lubricants or anti-seize compounds on tapered bore or bushing surfaces. For complete installation instructions, refer to the sheet packaged with each bushing.