



Motor Brakes

MOTOR BRAKE COIL DATA

DODGE D-Series motor brakes are equipped with DC voltage coils which are capable of a variety of nameplate voltage possibilities. Please consult Voltage Notes below the chart for these capabilities.

Coil Voltage	3 and 6 Ft.-Lb		10 thru 50 Ft.-Lb	
	Current Draw (Amps)	Resistance (Ohms)	Current Draw (Amps)	Resistance (Ohms)
115/230 VAC 60 Hz (1)	0.19	562	0.28	387
230/460 VAC 60 Hz (2)	0.10	2078	0.14	1550
287/575 VAC 60 Hz (3)	0.09	2987	0.12	2245
104/208 VAC 60 Hz (4)	0.24	384	0.31	290
190/380 VAC 50 Hz (5)	0.13	1341	0.19	923
250/500 VAC 50 Hz	0.10	2336	0.13	1793
48 VDC	0.48	100	0.58	82
24 VDC	0.97	24.70	1.14	21.70
12 VDC	1.95	6.16	2.24	5.40

Voltage News:

- (1) 115/208-230 VAC 50 or 60 Hz, 133/265 VAC 60 Hz, 110-125 VDC
- (2) 208-230/460 VAC 50 or 60 Hz, 240/480 VAC 60 Hz, 220/440 VAC 50 Hz, 230 VDC
- (3) 287/575 VAC 60 Hz, 275/550 VAC 60 Hz, 300/600 VAC 60 Hz
- (4) 104/208 VAC 50 or 60 Hz, 100/200 VAC 60 Hz 90-95 VDC
- (5) 190/380 VAC 50 Hz, 260/400 VAC 60 Hz, 208/416 VAC 50 Hz

General Notes:

- (1) Current and Resistance values are approximate only.
- (2) Current and Resistance for other nameplate voltages may vary slightly. Consult DODGE Engineering for actual values
- (3) Coil Resistance is measured between leads B4 and B5.

ELECTRICAL CONNECTIONS

Standard DODGE D-Series motor brakes operate on single phase, dual voltage AC.

Connections should be made per Chart 1 (similar chart is also included in a label on the brake). To change the operating voltage, simply change the wiring connections per Chart 1.

When changing brake wiring connections for operation at another voltage, be sure to verify the brake's compatibility with the voltage desired.

Consult Instruction Manual #499765 for complete details on Electrical Connections of DODGE D-Series motor brakes.

CHART 1

Voltage	Power Line A	Power Line B	Insulate Together	Insulate Alone
AC Voltage-Low(1)	B1	B2	B3 & B5	B4
AC Voltage-High(1)	B1 B5	B2	-	B3 B4
DC Voltage-Low	B1	B2	B3 & B5	B4

Notes:

- (1) Unless specified, all brakes have dual voltage coils. For example, with a 230/460 VAC brake, low voltage = 230 VAC and high voltage = 460 VAC.

AC Voltage - Low and DC Voltage

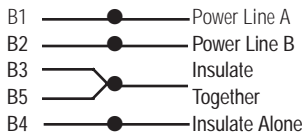

AC Voltage - High

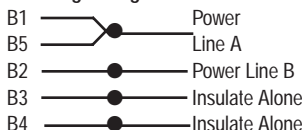

FEATURES/BENEFITS PAGE PT2-3	SPECIFICATION/HOW TO ORDER PAGE PT2-4	SELECTION/DIMENSIONS PAGE PT2-5	MODIFICATION PAGE PT2-11
---------------------------------	--	------------------------------------	-----------------------------



Clutch/Brake Modules

TECHNICAL DATA

Module Size	Static Torque (Lb.-Ft.)	Inertia (Lb.-Ft.(²))		Unit Weight (Lbs.)	90 VDC				24 VDC				6 VDC			
		Rotor & Hub	Armature & Shaft		Clutch		Brake		Clutch		Brake		Clutch		Brake	
					Amps	Ohms	Amps	Ohms	Amps	Ohms	Amps	Ohms	Amps	Ohms	Amps	Ohms
DMCCB-50	22	.022	.017	11.8	.207	434	.196	460	.797	30.1	.800	30	3.23	.186	3.05	1.97
DMCCO-50		.022	.010	9.9	.207	434	---	---	.797	30.1	---	---	3.23	---	---	---
DMCBO-50		---	.009	6.1	---	---	.196	460	---	---	.800	30	---	---	3.05	1.97
DMCBX-50		---	.009	6.1	---	---	.196	460	---	---	.800	30	---	---	3.05	1.97
DMSCB-50		.023	.017	16.2	.207	434	.196	460	.797	30.1	.800	30	3.23	.186	3.05	1.97
DMSCO-50		.023	.010	14.3	.207	434	---	---	.797	30.1	---	---	3.23	.186	---	---
DMCCB-100	34	.050	.049	11.9	.208	432	.189	476	.805	29.8	.743	32.3	3.23	.186	2.91	2.06
DMCCO-100		.050	.027	10	.208	432	---	---	.805	29.8	---	---	3.23	.186	---	---
DMCBO-100		---	.026	6.2	---	---	.189	476	---	---	.743	32.3	---	---	2.91	2.06
DMCBX-100		---	.026	6.2	---	---	.189	476	---	---	.743	32.3	---	---	2.91	2.06
DMCCB-180	34	.051	.050	15.9	.208	432	.189	476	.805	29.8	.743	32.3	3.23	.186	2.91	2.06
DMCCO-180		.051	.028	12.5	.208	432	---	---	.805	29.8	---	---	3.23	.186	---	---
DMCBO-180		---	.027	7.2	---	---	.189	476	---	---	.743	32.3	---	---	2.91	2.06
DMCBX-180		---	.027	7.2	---	---	.189	476	---	---	.743	32.3	---	---	2.91	2.06
DMSCB-180		.049	.050	19.6	.208	432	.189	476	.805	29.8	.743	32.3	3.23	.186	2.91	2.06
DMSCO-180		.049	.028	16.2	.208	432	---	---	.805	29.8	---	---	3.23	.186	---	---
DMCCB-210	100	.233	.196	44.2	.390	231	.360	250	1.61	14.9	1.480	16.2	6.67	.900	6.59	0.91
DMCCO-210		.233	.113	38.2	.390	231	---	---	1.61	14.9	---	16.2	6.67	.900	---	---
DMCBO-210		---	.100	28	---	---	.360	250	---	---	1.480	---	---	---	6.59	0.91
DMCBX-210		---	.100	28	---	---	.360	250	---	---	1.480	---	---	---	6.59	0.91
DMSCB-210		.240	.190	59.5	.390	231	.360	250	1.61	14.9	1.480	16.2	6.67	.900	6.59	0.91
DMSCO-210		.240	.190	53.5	.390	231	---	---	1.61	14.9	---	16.2	6.67	.900	---	---
DMCCB-256	100	.230	.200	44.4	.390	231	.360	250	1.61	14.9	1.480	16.2	6.67	.900	6.59	0.91
DMCCO-256		.230	.110	38.4	.390	231	---	---	1.61	14.9	---	---	6.67	.900	---	---
DMCBO-256		---	.110	28.2	---	---	.360	250	---	---	1.480	16.2	---	---	6.59	0.91
DMCBX-256		---	.110	28.2	---	---	.360	250	---	---	1.480	16.2	---	---	6.59	0.91

Consult DODGE for other voltages



Shaft Mounted Clutches & Brakes

IEC SERIES SHAFT MOUNTED CLUTCHES

Unit Size	Static Torque (Lb-Ft.)	Max RPM	Inertia (Lb-Ft. ²)		90 VDC		24 VDC		6 VDC		Wt.(Lbs.)
			Rotor & Sleeve	Armature & Sleeve	Amps	Ohms	Amps	Ohms	Amps	Ohms	
IEC-375	22	5000	0.022	0.01	0.207	434	0.797	30.1	3.23	1.86	5.5
IEC-475	34	4500	0.052	0.027	0.208	432	0.805	29.8	3.23	1.86	9
IEC-650	100	3600	0.214	0.107	0.39	231	1.61	14.9	6.67	0.9	19.5
IEC-825	175	3600	0.417	0.268	0.405	222	1.66	14.5	5.41	1.11	29

Consult DODGE for other voltages.

IEB SERIES SHAFT MOUNTED BRAKES/IPB SERIES FLANGE MOUNTED BRAKES

Unit Size	Static Torque (Lb-Ft.)	Max Speed RPM	Inertia (Lb-Ft ²) Armature & Hub	90 VDC		24 VDC		6 VDC		Brake Wt. (Lbs.)	Bore Range (In.)	DODGE TAPER Lock Bushing
				Amps	Ohms	Amps	Ohms	Amps	Ohms			
IEB/IPB-375	22	5000	.010	.196	460	.800	30.00	3.05	1.97	4	1/2" & 5/8"	N/A
IEB/IPB-475	34	4500	.029	.189	476	.743	32.30	2.91	2.06	6	1/2" to 1"	1008
IEB/IPB-650	100	3600	0.11	.360	250	1.48	16.20	6.59	0.91	11	1/2" to 1-7/16"	1310
IEB-825	175	3600	0.33	.405	222	1.66	14.50	5.41	1.11	19	1/2" to 1-11/16"	1615

Consult DODGE for other voltages.

* See page CB-53 (1-1R)

EATURES/BENEFITS PAGE PT2-3	SPECIFICATION/HOW TO ORDER PAGE PT2-4	SELECTION/DIMENSIONS PAGE PT2-5	MODIFICATION PAGE PT2-11
--------------------------------	--	------------------------------------	-----------------------------



Clutch/Brake Modules ALLOWABLE CYCLE RATES

DMCCB-50

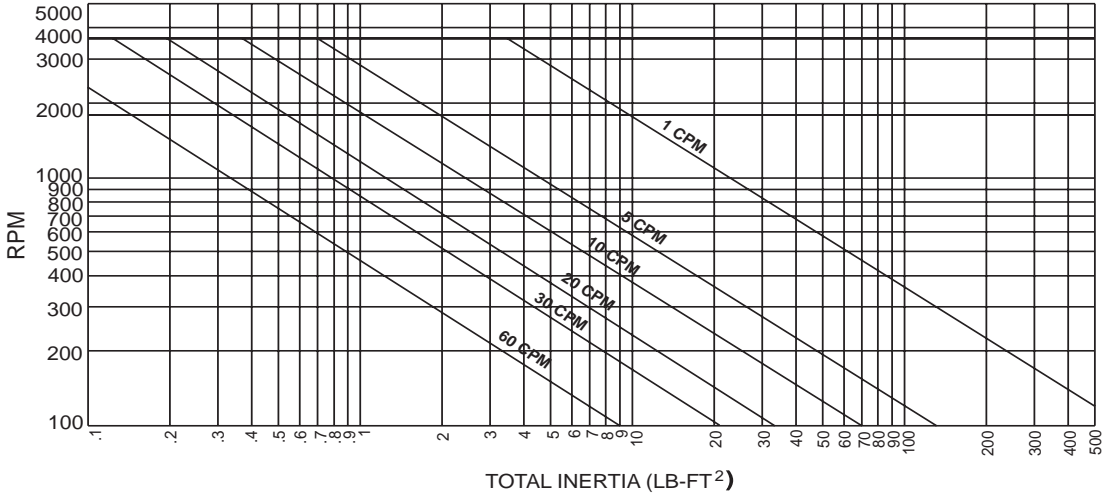

DMCCB-100

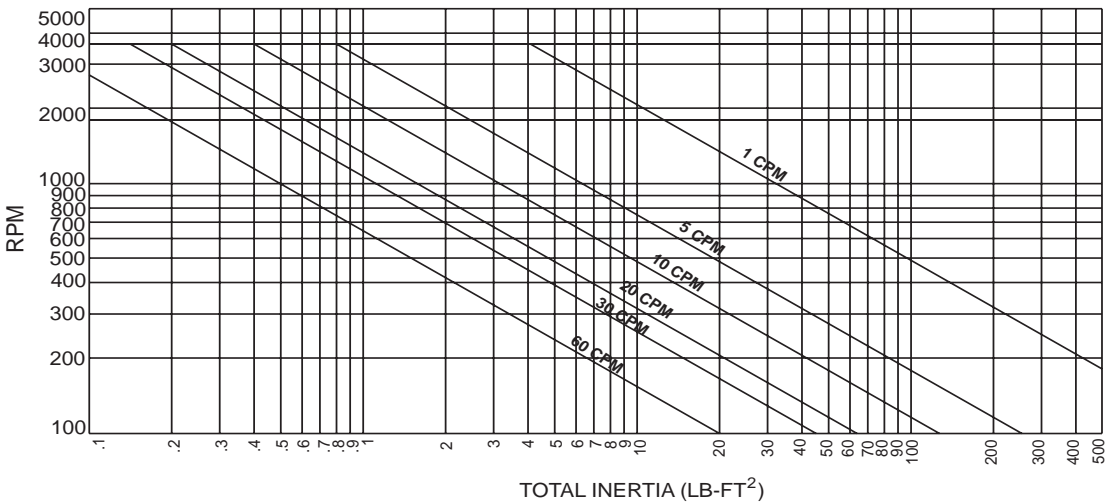

NOTES:

1. Consult DODGE for cycle rates that exceed chart.
2. Max. coil temperature 2505F
3. Motor fan cooled
4. 100% current

FEATURES/BENEFITS PAGE PT2-3	SPECIFICATION/HOW TO ORDER PAGE PT2-4	SELECTION/DIMENSIONS PAGE PT2-5	MODIFICATION PAGE PT2-11
---------------------------------	--	------------------------------------	-----------------------------



Clutch/Brake Modules
ALLOWABLE CYCLE RATES

DMCCB-180

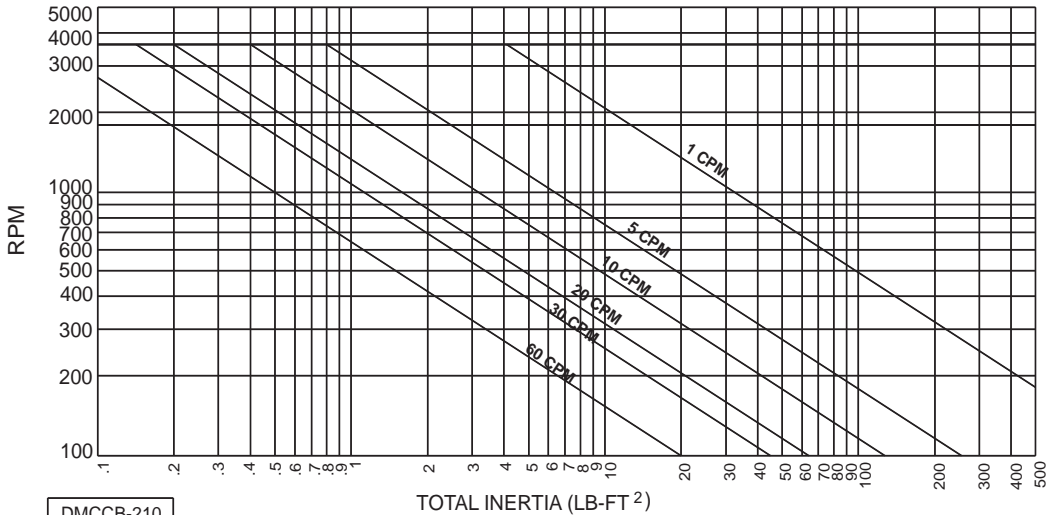

DMCCB-210

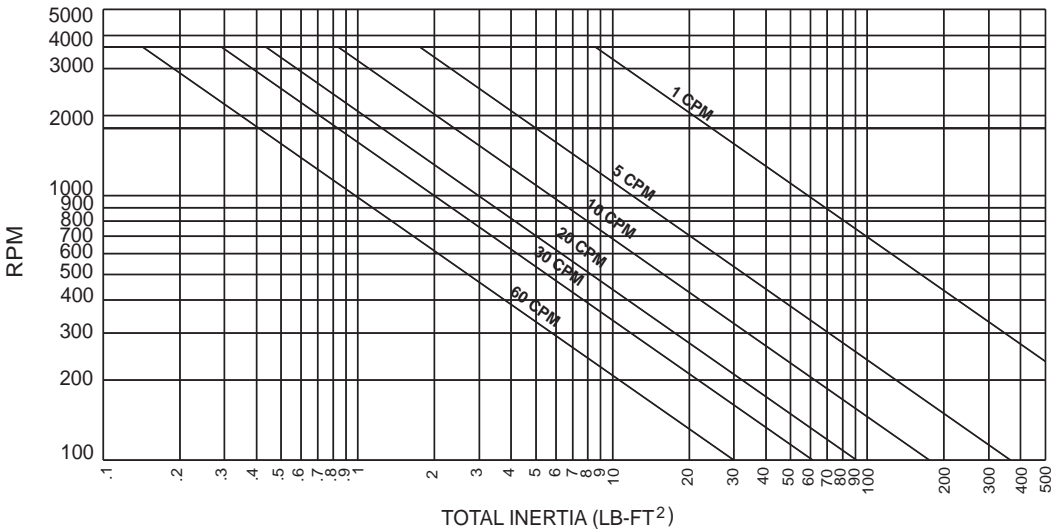

- NOTES:**
1. Consult DODGE for cycle rates that exceed chart.
 2. Max. coil temperature 2505F
 3. Motor fan cooled
 4. 100% current

FEATURES/BENEFITS PAGE PT2-3	SPECIFICATION/HOW TO ORDER PAGE PT2-4	SELECTION/DIMENSIONS PAGE PT2-5	MODIFICATION PAGE PT2-11
---------------------------------	--	------------------------------------	-----------------------------



Clutch/Brake Modules ALLOWABLE CYCLE RATES

DMCCB-256

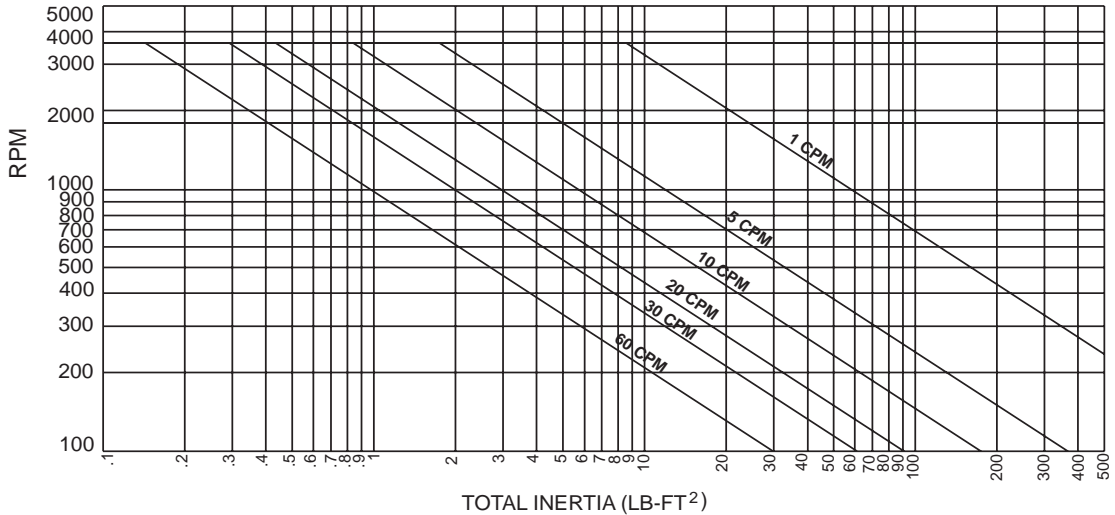
**NOTES:**

1. Consult DODGE for cycle rates that exceed chart.
2. Max. coil temperature 2505F
3. Motor fan cooled
4. 100% current



Clutch/Brake Modules
ALLOWABLE CYCLE RATES

DMCCO-50

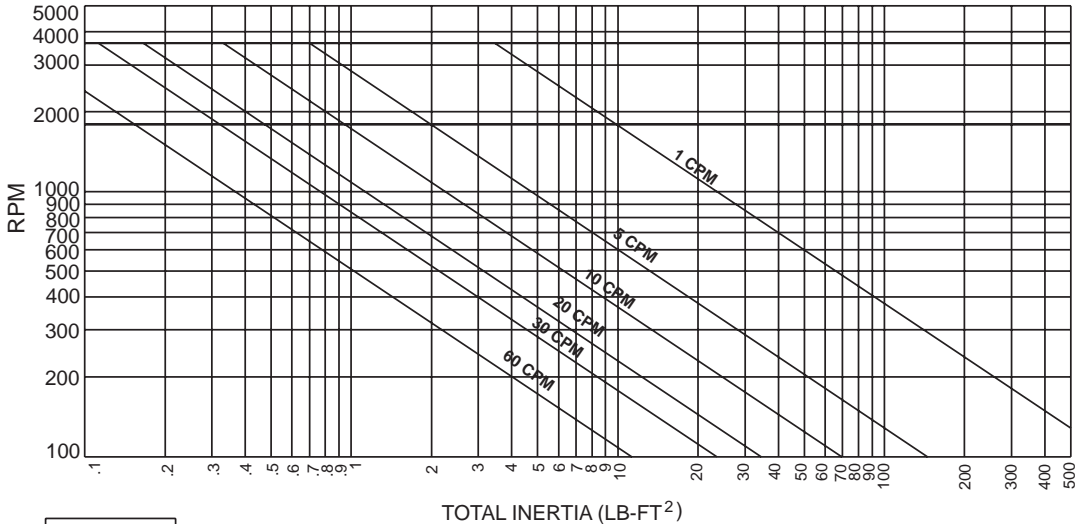

DMCCO-100

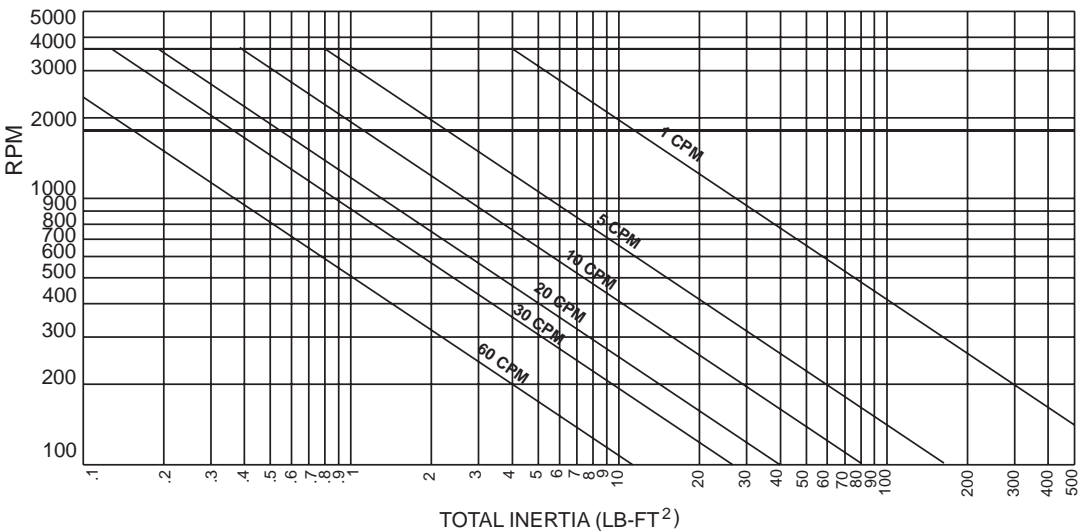

NOTES:

1. Consult DODGE for cycle rates that exceed chart.
2. Max. coil temperature 2505F
3. Motor fan cooled
4. 100% current

FEATURES/BENEFITS PAGE PT2-3	SPECIFICATION/HOW TO ORDER PAGE PT2-4	SELECTION/DIMENSIONS PAGE PT2-5	MODIFICATION PAGE PT2-11
---------------------------------	--	------------------------------------	-----------------------------



Clutch/Brake Modules ALLOWABLE CYCLE RATES

DMCCO-180

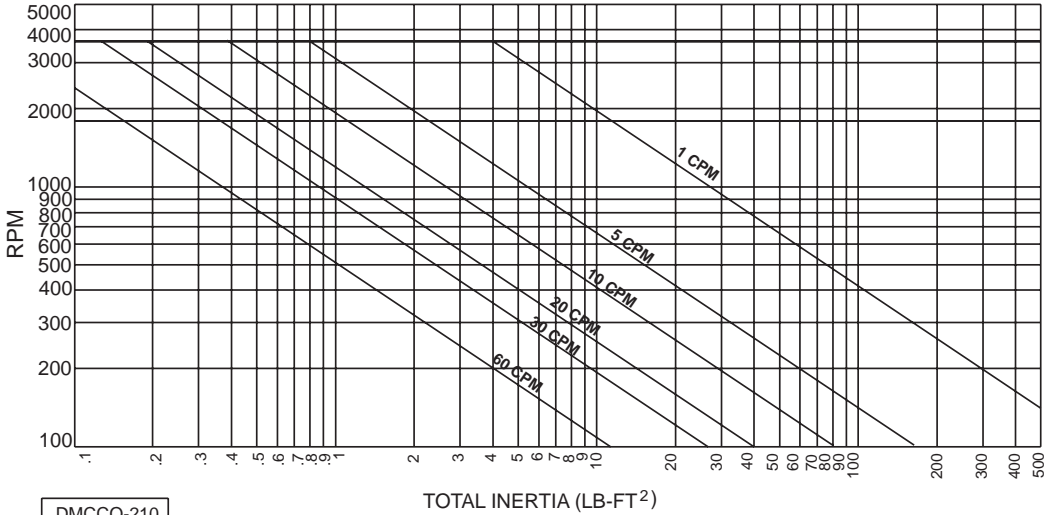

DMCCO-210

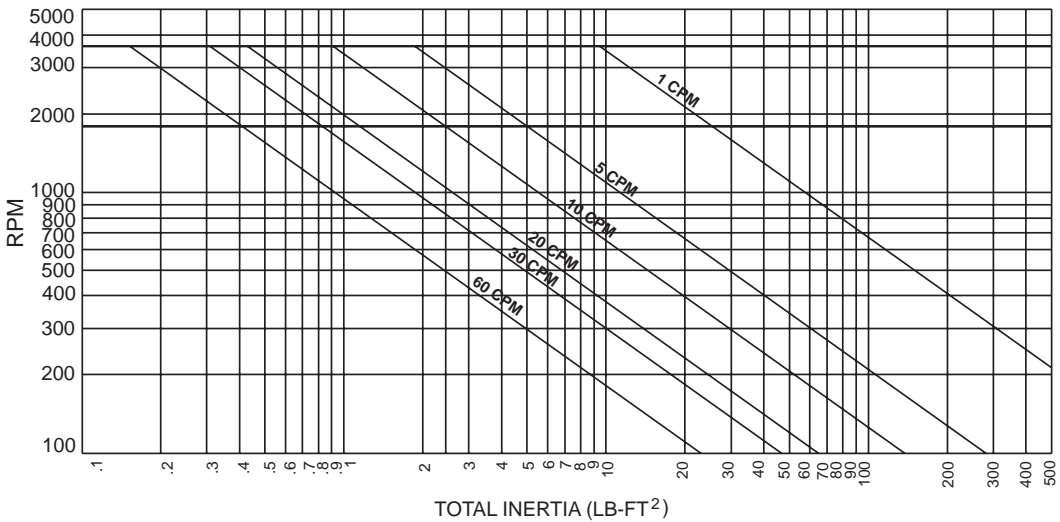

- NOTES:
1. Consult DODGE for cycle rates that exceed chart.
 2. Max. coil temperature 2505F
 3. Motor fan cooled
 4. 100% current



**Clutch/Brake Modules
ALLOWABLE CYCLE RATES**

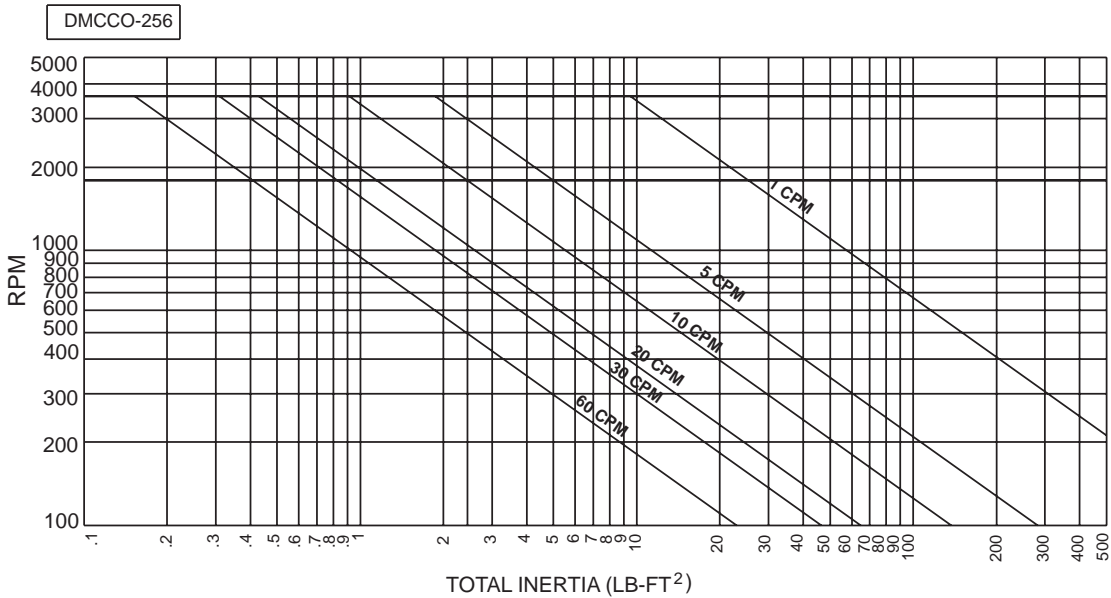

NOTES:

1. Consult DODGE for cycle rates that exceed chart.
2. Max. coil temperature 2505F
3. Motor fan cooled
4. 100% current

FEATURES/BENEFITS PAGE PT2-3	SPECIFICATION/HOW TO ORDER PAGE PT2-4	SELECTION/DIMENSIONS PAGE PT2-5	MODIFICATION PAGE PT2-11
---------------------------------	--	------------------------------------	-----------------------------



Clutch/Brake Modules ALLOWABLE CYCLE RATES

DMCBO-50

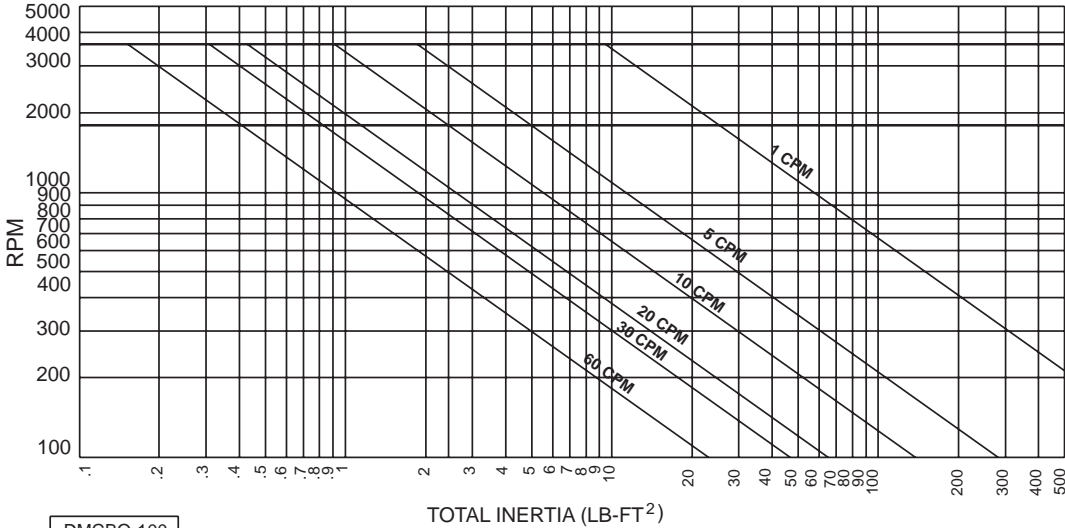

DMCBO-100

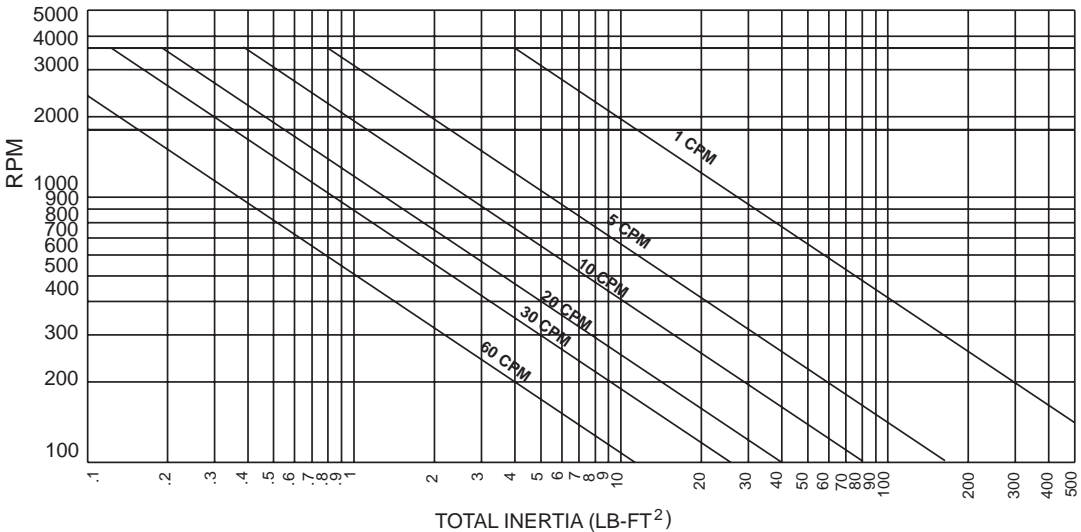

NOTES:

1. Consult DODGE for cycle rates that exceed chart.
2. Max. coil temperature 2505F
3. Motor fan cooled
4. 100% current



Clutch/Brake Modules
ALLOWABLE CYCLE RATES

DMCBO-180

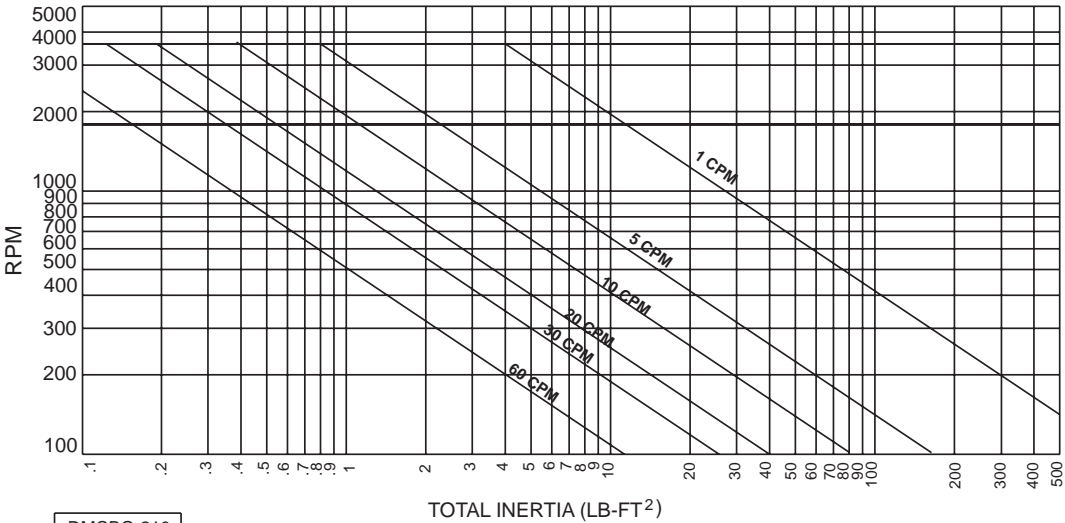

DMCBO-210

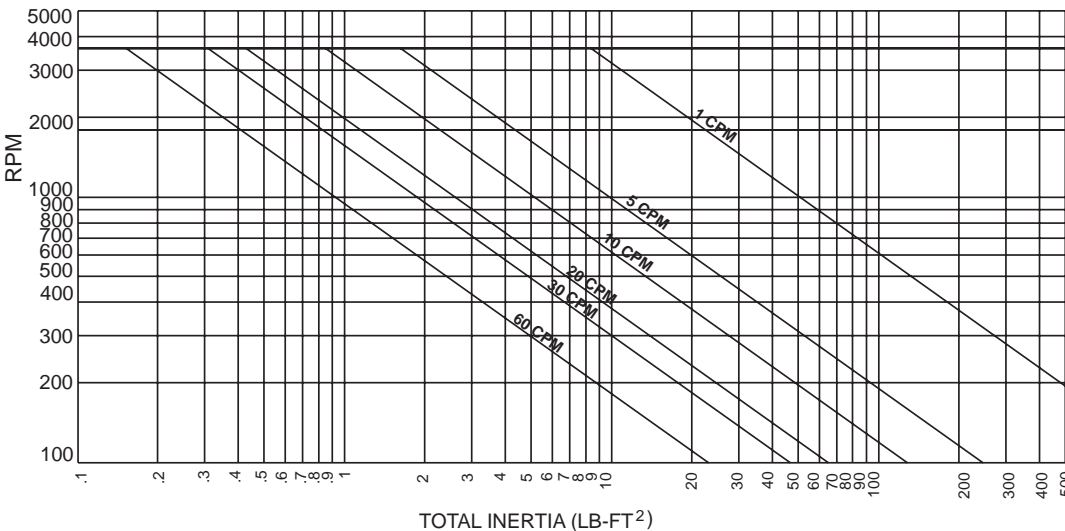

- NOTES:
 1. Consult DODGE for cycle rates that exceed chart.
 2. Max. coil temperature 2505F
 3. Motor fan cooled
 4. 100% current

FEATURES/BENEFITS PAGE PT2-3	SPECIFICATION/HOW TO ORDER PAGE PT2-4	SELECTION/DIMENSIONS PAGE PT2-5	MODIFICATION PAGE PT2-11
---------------------------------	--	------------------------------------	-----------------------------



Clutch/Brake Modules ALLOWABLE CYCLE RATES

DMCBO-256

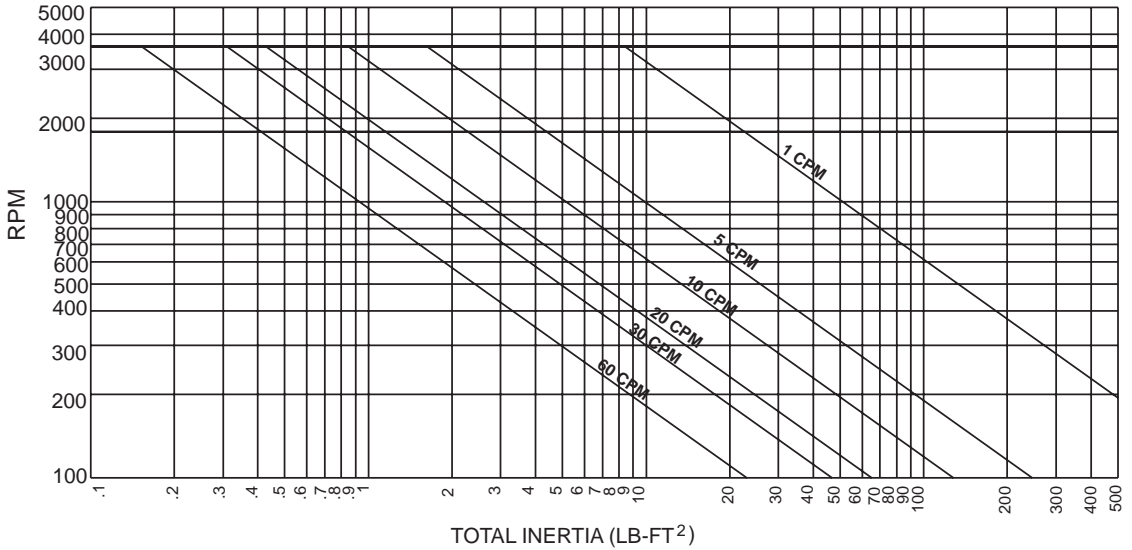

- NOTES:
1. Consult DODGE for cycle rates that exceed chart.
 2. Max. coil temperature 2505F
 3. Motor fan cooled
 4. 100% current

FEATURES/BENEFITS PAGE PT2-3	SPECIFICATION/HOW TO ORDER PAGE PT2-4	SELECTION/DIMENSIONS PAGE PT2-5	MODIFICATION PAGE PT2-11
---------------------------------	--	------------------------------------	-----------------------------



Clutch/Brake Modules
ALLOWABLE CYCLE RATES

IEC-825

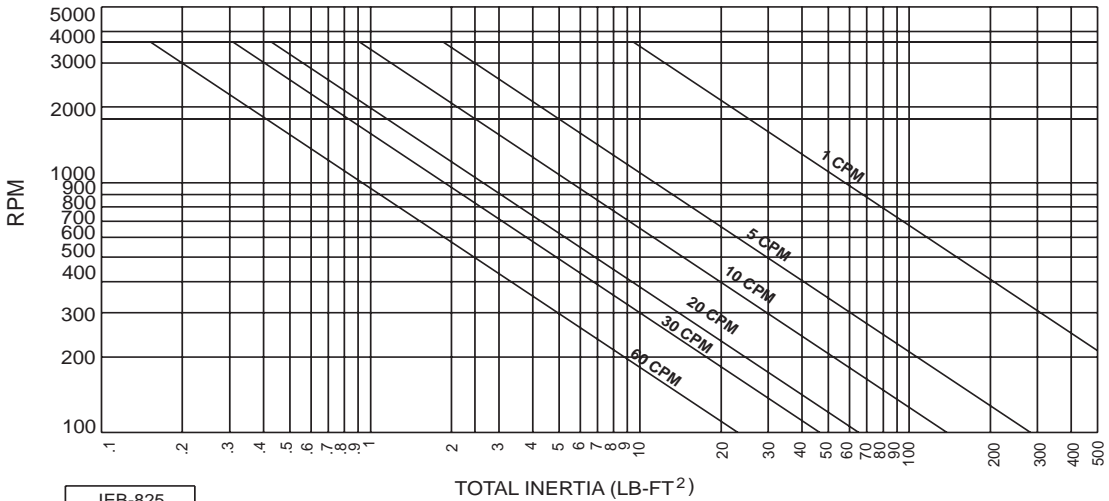

IEB-825

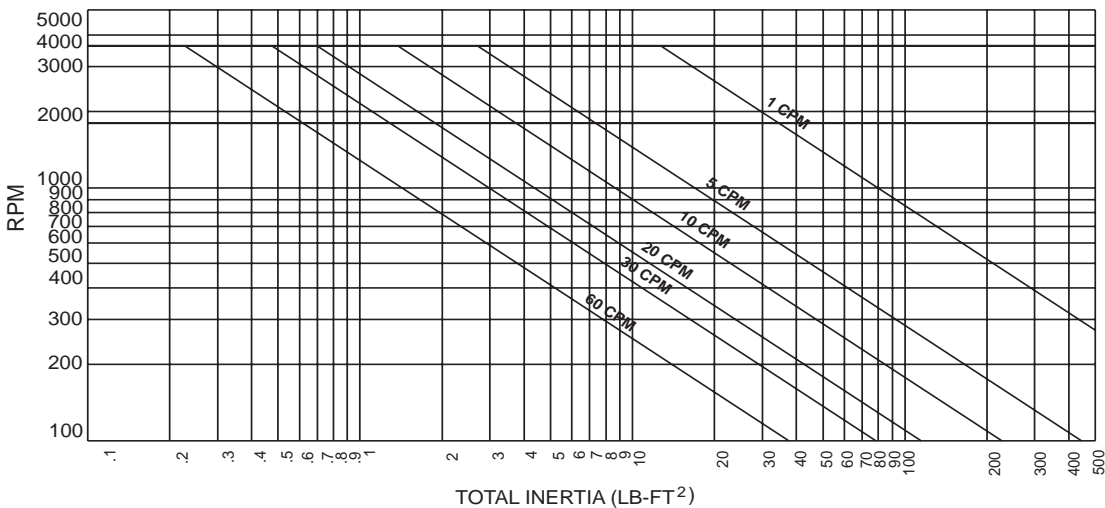

NOTES:

1. Consult DODGE for cycle rates that exceed chart.
2. Max. coil temperature 2505F
3. Motor fan cooled
4. 100% current

FEATURES/BENEFITS PAGE PT2-3	SPECIFICATION/HOW TO ORDER PAGE PT2-4	SELECTION/DIMENSIONS PAGE PT2-5	MODIFICATION PAGE PT2-11
---------------------------------	--	------------------------------------	-----------------------------



ENGINEERING/ TECHNICAL



Fractional HP

CLUTCHES

SL Series Technical Data

UNIT SIZE	Static Torque Lb.-In.	Inertia Lb.-In. ²		Wgt. Oz.	90 v DC		24 v DC	
		Rotor	Arm & Hub		Amps	Ohms	Amps	Ohms
SL-08	2.5	.002	.0015	2	.046	1977	.117	205
SL-11	6	.0058	.0029	3.2	.047	1930	.198	121
SL-15	10	.060	.0031	3.8	.042	2150	.183	132
SL-17	15	.061	.036	11	.066	1369	.289	83
SL-19	25	.082	.047	12	.074	1213	.294	81.6
SL-22	50	.215	.079	20	.079	1140	.322	74.6
SL-26	80	.362	.292	28	.088	1024	.358	67.1
SL-30	125	.610	.561	50	.091	988	.378	65.3
SL-42	250	2.50	2.30	85	.124	722	.468	51.2

BSL Series Technical Data

UNIT SIZE	Static Torque Lb.-In.	Inertia Lb.-In. ²		Wgt. Oz.	90 v DC		24 v DC	
		Rotor	Arm & Hub		Amps	Ohms	Amps	Ohms
BSL-26	80	.29	.53	38	.088	1024	.358	67.1
BSL-42	250	2.25	4.99	94	.124	722	.468	51.2

SO Series Technical Data

UNIT SIZE	Static Torque Lb.-In.	Inertia Lb.-In. ²		Wgt. Oz.	90 v DC		24 v DC	
		Rotor	Arm & Hub		Amps	Ohms	Amps	Ohms
SO-08	2.5	.002	.0011	2	.046	1977	.117	205
SO-11	6	.0058	.0024	3.2	.047	1930	.198	121
SO-15	10	.06	.026	3.8	.042	2150	.183	132
SO-17	15	.061	.031	11	.066	1369	.289	83
SO-19	25	.082	.042	12	.074	1213	.294	81.3
SO-22	50	.215	.070	20	.079	1140	.322	74.6
SO-26	80	.362	.320	28	.088	1024	.358	67.1
SO-30	125	.61	.561	45	.091	988	.378	65.3
SO-42	250	2.50	2.30	80	.124	722	.468	51.2

BRAKES

FB Series Technical Data

UNIT SIZE	Static Torque Lb.-In.	Inertia Lb.-In. ²		Wgt. Oz.	90 v DC		24 v DC	
		Arm & Hub			Amps	Ohms	Amps	Ohms
FB-08	2.5	.0011		2	.046	1977	.117	205
FB-11	6	.0024		3.2	.047	1930	.198	121
FB-15	10	.026		3.8	.042	2150	.183	132
FB-17	15	.031		11	.066	1369	.289	83
FB-19	25	.042		12	.074	1213	.294	81.6
FB-22	50	.070		20	.079	1140	.322	74.6
FB-26	10	.320		26	.088	1024	.358	67.1
FB-30	125	.561		35	.091	988	.378	65.3
FB-42	250	2.30		60	.124	722	.468	51.2

FSB Series Technical Data

UNIT SIZE	Static Torque Lb.-In.	Inertia Lb.-In. ²		Wgt. Oz.	90 v DC		24 v DC		120 v AC	
		Armature & Hub			Amps	Ohms	Amps	Ohms	Amps	Ohms
FSB-001	1	.0004		2	.051	1880	.220	117	.041	N.A.
FSB-002	3	.0017		3	.064	2177	.190	132	.050	N.A.
FSB-007	7	.0133		15	.059	1520	.247	97.3	.045	N.A.
FSB-015	15	.0133		16	.098	922	.369	65.1	.077	N.A.
FSB-035	35	.084		33	.093	964	.394	61	.073	N.A.
FSB-050	50	.084		36	.194	465	.717	35.5	.140	N.A.
FSB-100	100	.205		64	.180	501	.707	34	.142	N.A.

FSBR Series Technical Data

UNIT SIZE	Static Torque Lb.-In.	Inertia Lb.-In. ²		Wgt. Oz.	90 v DC		24 v DC		120 v AC	
		Armature & Hub			Amps	Ohms	Amps	Ohms	Amps	Ohms
FSB-001	7	.0133		11	.059	1520	.247	97.3	.045	N.A.
FSB-002	15	.0133		12	.098	922	.369	65.1	.077	N.A.
FSB-007	35	.084		24	.093	964	.394	61	.073	N.A.
FSB-015	50	.084		27	.194	465	.717	35.5	.140	N.A.
FSB-035	100	.205		56	.180	501	.707	34	.142	N.A.

Consult DODGE for other voltages.