



SELECTION



Fluid Couplings

FLUID COUPLING SELECTION

HP	RPM		
	1800	1500	1200
5	8	8	9
7.50	8	9	11
10	8	9	12
15	9	11	12
20	11	12	13
25	11	12	13
30	11	12	15
40	12	13	15
50	13	15	17
60	13	15	17
75	15	15	17
100	15	17	19
125	17	19	21
150	17	19	21
200	19	21	24
250	21	21	24
300	21	24	27
350	21	24	27
400	24	24	27
500	24	27	29



SELECTION/DIMENSIONS



Fluid Couplings

PART NUMBERS

KSD DRIVE ACCEPTS "OD" STYLE SHEAVE	
PART #	PART DESCRIPTION
118780	7 KSD-QD SDS W/ 1-1/8 COLLET
118781	8 KSD-QD SDS W/ 1-1/8 COLLET
118782	9 KSD-QD SK W/ 1-3/8 COLLET
118783	11 KSD-QD SF W/ 1-7/8 COLLET
118784	12 KSD-QD E W/ 2-1/8 COLLET
118785	13 KSD-QD E W/ 2-1/8 COLLET
118786	13 KSD-QD E W/ 2-3/8 COLLET
118648	15 KSD-QD F W/ 2-3/8 COLLET
118649	15 KSD-QD F W/ 2-7/8 COLLET
118650	17 KSD-QD J W/ 3-3/8 COLLET
118651	19 KSD-QD J W/ 3-3/8 COLLET
118652	21 KSD-QD M W/ 3-3/8 FINISH BORE
118653	24 KSD-QD M W/ 3-3/8 FINISH BORE

DELAY FILL

CKSD DRIVE ACCEPTS "OD" STYLE SHEAVE	
PART #	PART DESCRIPTION
118654	11 CKSD-QD SF W/ 1-7/8 COLLET
118655	12 CKSD-QD E W/ 2-1/8 COLLET
118656	13 CKSD-QD E W/ 2-1/8 COLLET
118657	13 CKSD-QD E W/ 2-3/8 COLLET
118658	15 CKSD-QD F W/ 2-3/8 COLLET
118659	15 CKSD-QD F W/ 2-7/8 COLLET
118660	17 CKSD-QD J W/ 3-3/8 COLLET
118661	19 CKSD-QD J W/ 3-3/8 COLLET
118662	21 CKSD-QD M W/ 3-3/8 FINISH BORE
118663	24 CKSD-QD M W/ 3-3/8 FINISH BORE

KSD DRIVE ACCEPTS BOLT-ON STYLE SHEAVE	
PART #	PART DESCRIPTION
118787	15 KSD FLUID CPLG W/ 2-3/8 F.B.
118788	15 KSD FLUID CPLG W/ 2-7/8 F.B.
118789	15 KSD FLUID CPLG 2-3/8 COLLET
118790	15 KSD FLUID CPLG 2-7/8 COLLET
118792	17 KSD FLUID CPLG W/ 3-3/8 F.B.
118793	17 KSD FLUID CPLG 3-3/8 COLLET
118794	17 KSD FLUID CPLG 2-3/8 COLLET
118795	19 KSD FLUID CPLG W/ 3-3/8 F.B.
118796	19 KSD FLUID CPLG 3-3/8 COLLET
118797	21 KSD FLUID CPLG W/ 3-3/8 F.B.
118798	24 KSD FLUID CPLG W/ 3-3/8 F.B.

The motor shaft for sizes 15 KSD F.B. style and up must be tapped.

* For non-standard sheaves contact DODGE Drive Components.



Collet Mount: Available on most sizes for ease of installation.

KSD BOLT-ON SHEAVES *		
PT NO.	KSD#	DESCRIPTION
118740	15	3GR 5V 12.5
118743	15	4GR 5V 9.75
118744	15	4GR 5V 10.3
118745	15	4GR 5V 10.9
118746	15	4GR 5V 11.3
118747	15	4GR 5V 11.8

KSD BOLT-ON SHEAVES *		
PT NO.	KSD#	DESCRIPTION
118750	17	4GR 5V 12.5
118755	17	5GR 5V 10.9
118746	17	5GR 5V 11.3
118757	17	5GR 5V 11.8
118758	17	5GR 5V 12.5
118759	17	5GR 5V 13.2
118762	17	6GR 5V 10.9
118763	17	6GR 5V 11.3
118749	17	4GR 5V 11.8
118764	19	6GR 5V 12.5
118765	19	6GR 5V 13.2
118769	19	8GR 5V 10.9
118770	19	8GR 5V 11.3
118771	19	8GR 5V 11.8
118772	21	5GR 8V 14.0
118774	21	6GR 8V 13.2
118775	21	6GR 8V 14.0
118776	21	8GR 8V 13.2
118777	21	8GR 8V 14.0
118778	24	8GR 8V 14.0
118779	24	10GR 8V 13.2



Fluid Couplings

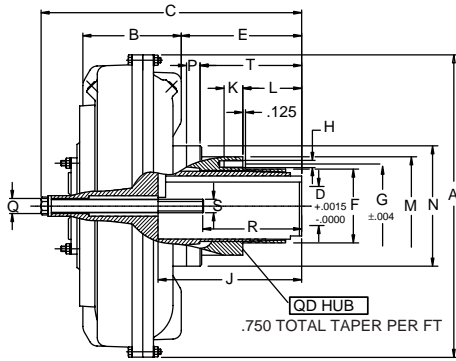

KSD-QD

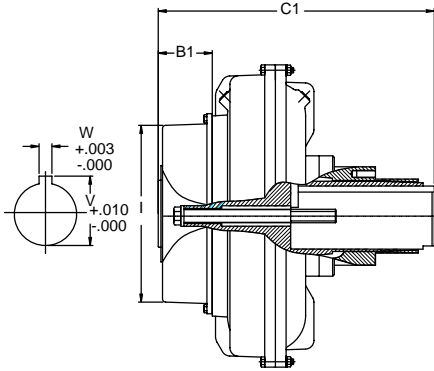

CKSD-QD

DIMENSIONAL DATA SHEET – KSD & CKSD

Size	D Bore	A	KSD		CKSD		E	F	G	H		J	K	L	M	N	P	Q	R	S	T	QD Hub Size	Weight (lb) Less Oil		Oil U.S. Gal. max.		
			B	B1	C Max	C1 Max				#	Dia												KSD-QD	CKSD-QD	KSD-QD	CKSD-QD	
7	1.375	8.98	3.03		7.10	-	2.77	2.19	2.69	3	1/4-20	2.40	0.6	1.2	3.1	4.5	0.6	1/2-13 UNC		1.94	SDS	13.4		0.24			
	1.125																										
	0.875																										
8	1.375	10.08	3.58		7.33	-	2.61	2.19	2.69	3	1/4-20	2.40	0.6	1.2	3.1	4.5	0.6	1/2-13 UNC		1.94	SDS	14.8		0.40			
	1.125																										
9	1.625	11.61	3.78		9.80	-	3.98	2.81	3.31	3	5/16-18	3.31	0.7	1.5	3.9	5.0	1.0	3/4-10 UNC		2.48	SK	28.7		0.52			
11	1.875	12.80	4.21		10.20	-	3.86	3.13	3.88	3	3/8-16	4.00	0.8	1.5	4.6	5.5	0.8	3/4-10 UNC		2.76	SF	34.2		0.73			
	1.625																										
12	2.125	14.57	4.80	3.15	11.56	13.05	5.10	3.83	5.00	3	1/2-13	4.25	1.1	1.9	6.0	6.1	0.9	3/4-10 UNC		3.98	E	50.7	57.2	1.08	1.27		
	1.875																										
	1.625																										
13	2.375	15.67	5.39	3.15	13.90	14.96	6.42	3.83	5.00	3	1/2-13	4.25	1.1	2.8	6.0	7.0	1.1	3/4-10 UNC		5.22	E	73.9	80.5	1.37	1.53		
	2.125																										
	1.875																										
15	2.875	18.11	5.95	3.62	15.12	17.24	7.68	4.44	5.63	3	9/16-12	7.00	1.2	3.9	6.6	8.0	1.9	7/8-9	5.35	3/4-10	UNC	6.02	F	107	115.8	2.02	2.27
	5.63											3.90															
17	3.375	20.47	6.69	3.98	17.91	20.32	9.65	5.15	6.25	3	5/8-11	8.25	1.4	4.3	8.3	8.3	2.8	11/4-7	6.30	7/8-9	UNC	8.45	J	156	169.2	3.09	3.59
	7.00											5.00															
19	3.375	22.24	7.48	3.98	17.91	20.32	8.86	5.15	6.25	3	5/8-11	8.25	1.4	4.3	8.3	8.3	2.2	11/4-7	6.30	7/8-9	UNC	8.45	J	174	187.2	3.75	4.36
	7.00											5.00															
21	3.875	24.41	8.07	4.53	21.46	24.41	11.81	6.50	7.88	4	3/4-10	1.00	1.6	7.1	9.8	9.8	2.2	11/4-7	6.56	7/8-9	UNC	11.22	M	270	292	5.02	6.08
	3.375				19.88	22.84	10.24					0.88						6.51	9.65								
24	3.875	27.95	9.02	4.53	21.46	24.41	10.87	6.50	7.88	4	3/4-10	1.00	1.6	7.1	9.8	9.8	1.4	11/4-7 UNC	6.56	7/8-9 UNC	11.22	M	307	329	7.50	8.24	

• Max Bore



SELECTION/DIMENSIONS



Fluid Couplings

PART NUMBERS

FLUID COUPLING ACCEPTS GEAR CPLG HALVES *

PART #	PART DESCRIPTION
118625	7 KCM - LESS 1.0S GEAR COUPLING
118626	8 KCM - LESS 1.0S GEAR COUPLING
118627	9 KCM - LESS 1.5S GEAR COUPLING
118628	11 KCM - LESS 1.5S GEAR COUPLING
118629	12 KCM - LESS 1.5S GEAR COUPLING
118630	13 KCM - LESS 1.5S GEAR COUPLING
118631	15 KCM - LESS 2.5S GEAR COUPLING
118632	17 KCM - LESS 2.5S GEAR COUPLING
118633	19 KCM - LESS 2.5S GEAR COUPLING
118634	21 KCM - LESS 2.5S GEAR COUPLING
118635	24 KCM - LESS 2.5S GEAR COUPLING
118636	27 KCM - LESS 3.5E GEAR COUPLING
118637	29 KCM - LESS 3.5E GEAR COUPLING

DELAY - FILL

PART #	PART DESCRIPTION
118638	11 CKCM - LESS 1.5S GEAR COUPLING
118639	12 CKCM - LESS 1.5S GEAR COUPLING
118640	13 CKCM - LESS 1.5S GEAR COUPLING
118641	15 CKCM - LESS 2.5S GEAR COUPLING
118642	17 CKCM - LESS 2.5S GEAR COUPLING
118643	19 CKCM - LESS 2.5S GEAR COUPLING
118644	21 CKCM - LESS 2.5S GEAR COUPLING
118645	24 CKCM - LESS 2.5S GEAR COUPLING
118646	27 CKCM - LESS 3.5E GEAR COUPLING
118647	29 CKCM - LESS 3.5E GEAR COUPLING

* Gear Coupling Kit ordered separately

GEAR COUPLINGS: For use with Fluid Couplings style KCM and CKCM. Order one kit per fluid coupling - advise bore size.

Size	Goes w/Fluid Cplg.	Max Bore
1.0 SB	KCM/CKCM 7, 8	1.625"
1.5 SB	KCM/CKCM 9-13	2.375"
2.5 SB	KCM/CKCM 15-24	3.75"
3.5 EB	KCM/CKCM 27, 29	4.75"

SB = Shrouded Bolt

EB = Exposed Bolt



Fluid Couplings

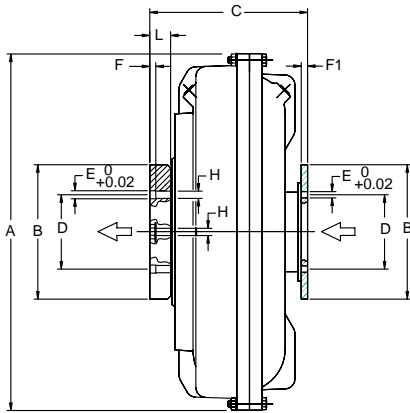

KCM

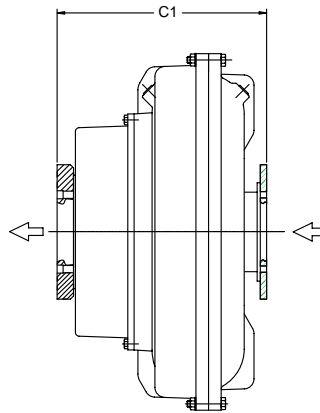

CKCM

DIMENSIONAL DATA SHEET – KCM & CKCM

Size	A	B	C		D	E		H	Gear Coupling Size	Weight (lb) Less Oil		Oil U.S. Gal. max.	
			KCM	CKCM		#	DIA			KCM	CKCM	KCM	CKCM
7	8.98	4.57	5.51	-	3.75	6	0.25	1/4-28 UNF	1	16	-	0.24	-
8	10.08	4.57	5.71	-	3.75	6	0.25	1/4-28 UNF	1	18	-	0.34	-
9	11.61	6.00	6.97	-	4.81	8	0.38	3/8-24 UNF	1.5	31	-	0.52	-
11	12.80	6.00	7.32	-	4.81	8	0.38	3/8-24 UNF	1.5	35	-	0.73	-
12	14.57	6.00	7.80	10.43	4.81	8	0.38	3/8-24 UNF	1.5	46	53	1.08	1.27
13	15.67	6.00	8.19	11.16	4.81	8	0.38	3/8-24 UNF	1.5	62	68	1.37	1.53
15	18.11	8.39	9.76	12.87	7.00	10	0.50	1/2-20 UNF	2.5	104	112	2.02	2.27
17	20.47	8.39	9.85	13.08	7.00	10	0.50	1/2-20 UNF	2.5	146	159	3.09	3.59
19	22.24	8.39	9.85	13.08	7.00	10	0.50	1/2-20 UNF	2.5	165	178	3.75	4.36
21	24.41	8.39	12.59	16.61	7.00	10	0.50	1/2-20 UNF	2.5	240	262	5.02	6.08
24	27.95	8.39	12.59	16.61	7.00	10	0.50	1/2-20 UNF	2.5	285	306	7.50	8.24
27	30.71	11.02	14.45	20.71	9.50	8	0.75	3/4-16 UNF	3.5	454	505	11.09	13.21
29	33.86	11.02	15.59	21.85	9.50	8	0.75	3/4-16 UNF	3.5	562	613	14.53	16.65
34	39.37	12.52	18.54	24.96	11.00	8	0.75	3/4-16 UNF	4	960	978	21.80	24.44



SELECTION/DIMENSIONS



Fluid Couplings

PART NUMBERS

PX STYLE FLUID CPLG - INCLUDES ELEMENT *

		DELAY FILL	
PART #	PART DESCRIPTION	PART #	PART DESCRIPTION
000423	11KCP X 1-5/8" FLUID CPLG-2517	000454	11CKCP X 1-5/8" FLUID CPLG-2517
000424	11KCP X 1-7/8" FLUID CPLG-2517	000455	11CKCP X 1-7/8" FLUID CPLG-2517
000426	12KCP X 1-5/8" FLUID CPLG-2517	000457	12CKCP X 1-5/8" FLUID CPLG-2517
000427	12KCP X 1-7/8" FLUID CPLG-2517	000458	12CKCP X 1-7/8" FLUID CPLG-2517
000429	13KCP X 1-7/8" FLUID CPLG-2517	000460	13CKCP X 1-7/8" FLUID CPLG-2517
000430	13KCP X 2-1/8" FLUID CPLG-2517	000461	13CKCP X 2-1/8" FLUID CPLG-2517
000431	13KCP X 2-3/8" FLUID CPLG-2517	000462	13CKCP X 2-3/8" FLUID CPLG-2517
000432	15KCP X 2-1/8" FLUID CPLG-3535	000463	15CKCP X 2-1/8" FLUID CPLG-3535
000433	15KCP X 2-3/8" FLUID CPLG-3535	000464	15CKCP X 2-3/8" FLUID CPLG-3535
000434	15KCP X 2-7/8" FLUID CPLG-3535	000465	15CKCP X 2-7/8" FLUID CPLG-3535
000435	17KCP X 2-3/8" FLUID CPLG-3535	000466	17CKCP X 2-3/8" FLUID CPLG-3535
000436	17KCP X 2-7/8" FLUID CPLG-3535	000467	17CKCP X 2-7/8" FLUID CPLG-3535
000437	17KCP X 3-3/8" FLUID CPLG-3535	000468	17CKCP X 3-3/8" FLUID CPLG-3535
000438	19KCP X 2-3/8" FLUID CPLG-3535	000469	19CKCP X 2-3/8" FLUID CPLG-3535
000439	19KCP X 2-7/8" FLUID CPLG-3535	000470	19CKCP X 2-7/8" FLUID CPLG-3535
000440	19KCP X 3-3/8" FLUID CPLG-3535	000471	19CKCP X 3-3/8" FLUID CPLG-3535
000441	21KCP X 2-3/8" FLUID CPLG-4040	000472	21CKCP X 2-3/8" FLUID CPLG-4040
000442	21KCP X 3-3/8" FLUID CPLG-4040	000473	21CKCP X 3-3/8" FLUID CPLG-4040
000443	24KCP X 2-3/8" FLUID CPLG-4040	000474	24CKCP X 2-3/8" FLUID CPLG-4040
000444	24KCP X 3-3/8" FLUID CPLG-4040	000475	24CKCP X 3-3/8" FLUID CPLG-4040
000445	24KCP X 3-7/8" FLUID CPLG-4040	000476	24CKCP X 3-7/8" FLUID CPLG-4040

Mounting of KCP and CKCP may require the motor shaft to be tapped.

Part #s include mechanism, element and coupling assembly.

* TAPER-LOCK bushing ordered separately.



Fluid Couplings

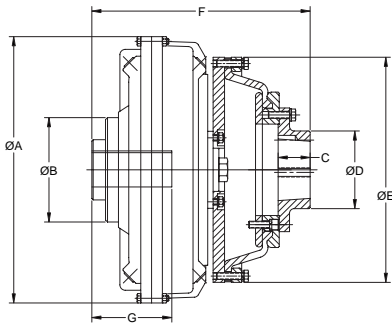

KCP-CONSTANT FILL

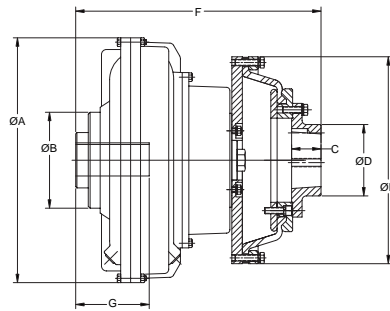

CKCP-DELAY FILL

DIMENSIONAL DATA SHEET – KCP & CKCP

Size	Fluid Coupling Bore	A	B	C	D	E	F		G	V		PH Element	PH Max Bore	TL Bushing	Max	Max
							KCP	CKCP		Torque (in-lb)	RPM					
11	1.625	12.80	5.04	1.75	4.25	10.31	11.76		3.75	1.796	0.375	PH96	2 11/16	2517	2300	3300
	4.38									1.972	0.5					
12	1.625	14.57	5.71	1.75	4.25	12.31	11.71	14.37	3.75	1.796	0.375	PH116	2 11/16	2517	3150	3200
	4.38									1.972	0.5					
13	1.875	15.67	7.06	1.75	4.25	13.81	13.58	15.94	4.38	2.093	0.5	PH131	2 11/16	2517	4700	3000
	5.00								2.350	0.5						
	5.63								2.480	0.625						
15	2.125	18.11	8.00	3.50	7.69	18.31	18.36	21.04	5.00	2.350	0.5	PH172	3 15/16	3535	6600	2600
	5.63								2.651	0.625						
	7.00								2.992	0.75						
17	2.375	20.47	8.86	3.50	7.69	18.31	19.23	22.38	5.63	2.651	0.625	PH172	3 15/16	3535	9200	2400
	7.63								3.635	0.875						
	7.00								2.651	0.625						
19	2.875	22.24	8.86	3.50	7.69	18.31	19.23	22.38	7.00	3.205	0.75	PH172	3 15/16	3535	12900	2200
	7.63								3.635	0.875						
	7.00								3.205	0.75						
21	3.375	24.41	9.84	4.00	8.63	20.31	22.79	26.73	8.25	3.635	0.875	PH192	4 7/16	4040	17300	2000
	7.00								3.205	0.75						
24	2.875	27.95	9.84	4.00	8.63	20.31	22.79	26.73	7.00	3.205	0.75	PH192	4 7/16	4040	24500	1800
	8.25								3.760	0.875						
	8.50								4.106	1						



NOTES



PT Components Reference Guide

Couplings

Clutches and Brakes

FLEXIDYNE

Fluid Couplings

FEATURES/BENEFITS
PAGE PT4-2

NOMENCLATURE
PAGE PT4-3

SELECTION
PAGE PT4-4