

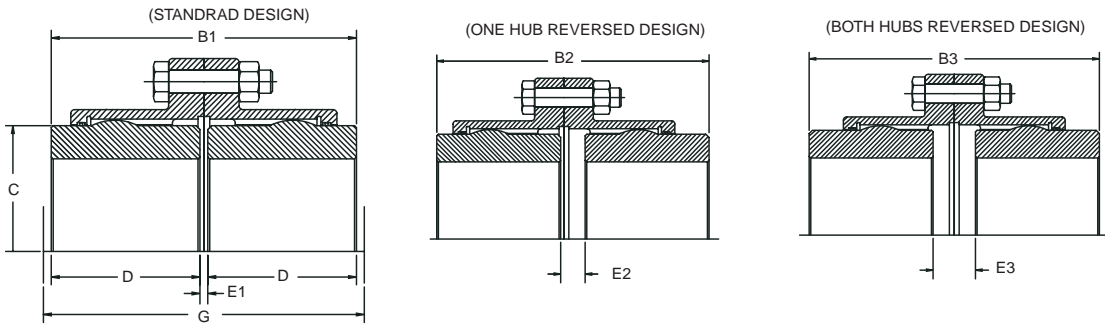

Gear Couplings



Size	Min. Bore [in.]	Max. Bore [in.] Standard Keyway		Max. Bore [in.] Shallow Keyway		HP/100+ RPM	Torque+ [lb-in.]	Max. RPM*	Max. Parallel Offset [in.]**	Approx. Weight [lbs.]***
		Flex Hub	Rigid Hub	Flex Hub	Rigid Hub					
1	0.438	1.625	2.188	1.750	2.313	12	7500	6000	0.055	9
1.5	0.438	2.125	2.813	2.250	3.063	30	18900	5500	0.060	19
2	0.563	2.750	3.500	3.000	3.750	50	31500	5000	0.085	34
2.5	0.813	3.250	4.250	3.375	4.500	90	56700	4400	0.105	55
3	1.188	4.000	4.875	4.250	5.250	150	94500	4000	0.115	86
3.5	1.563	4.625	5.625	4.875	6.125	240	151300	3500	0.130	135
4	1.813	5.500	6.500	5.625	6.875	350	220600	3000	0.150	195
4.5	1.813	6.000	7.375	6.438	8.000	480	302500	2700	0.175	268
5	2.563	6.875	8.375	7.000	8.875	690	434900	2500	0.200	394
5.5	3.063	7.750	9.250	7.875	9.875	910	573500	2200	0.220	526
6	4.063	8.625	10.125	8.750	11.000	1190	750000	2100	0.120	687
7	5.563	9.500	11.250	9.750	12.250	1600	1008400	2000	0.135	1017

+ Ratings are based on standard interference fit.

* For higher RPM applications, contact DODGE Customer Order Engineering at (864) 284-5700.

** Based on 1-1/2 degrees angular misalignment per gear mesh for sizes 1 through 5-1/2, 3/4 degree angular misalignment per gear mesh for sizes 6 and 7, and maximum bore. Flex-Rigid configurations do not accept parallel misalignment.

*** Approximate weight with minimum bore.

Size	Dimension [in.]								
	B1	B2	B3	C	D	E1	E2	E3	G
1	3-1/2	3-13/16	4-1/8	2-5/16	1-11/16	1/8	7/16	3/4	4-3/16
1.5	4	4-1/4	4-1/2	3	1-15/16	1/8	3/8	5/8	4-3/4
2	5	5-13/16	6-3/8	4	2-7/16	1/8	13/16	1-1/2	6
2.5	6-1/4	7-1/32	7-13/16	4-5/8	3-1/32	3/16	31/32	1-3/4	7-1/8
3	7-3/8	8-1/32	8-11/16	5-5/8	3-19/32	3/16	27/32	1-1/2	8-1/8
3.5	8-5/8	9-3/16	9-3/4	6-1/2	4-3/16	1/4	13/16	1-3/8	9-3/8
4	9-3/4	10-7/16	11-1/8	7-1/2	4-3/4	1/4	15/16	1-5/8	10-1/4
4.5	10-15/16	12	13-1/16	8-1/2	5-5/16	5/16	1-3/8	2-7/16	11-1/2
5	12-3/8	13-23/32	15-1/16	9-1/2	6-1/32	5/16	1-21/32	3	13
5.5	14-1/8	15-5/8	17-1/8	6-29/32	6-29/32	5/16	1-13/16	3-5/16	14-3/8
6	15-1/8	16-17/32	17-15/16	11-1/2	7-13/32	5/16	1-23/32	3-1/8	17
7	17-3/4	19-1/16	20-3/8	13	8-11/16	3/8	1-11/16	3	20

* Minimum space required to install and align coupling.

FEATURES/BENEFITS PAGE PT1-52	SPECIFICATION/NOMENCLATURE PAGE PT1-54	MODIFICATION/ACCESSORIES PAGE PT1-67	ENGINEERING/TECHNICAL PAGE PT1-69
----------------------------------	---	---	--------------------------------------



SELECTION/DIMENSIONS



Gear Couplings

(FLANGED SLEEVE AND RIGID HUB DETAILS)

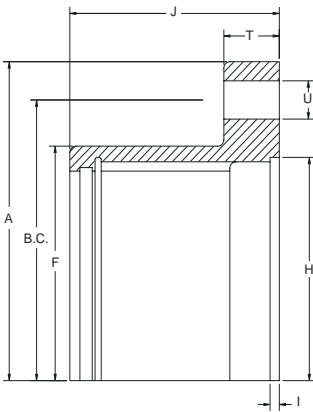

Size	Outside	Flange	Flange	Hub	Under-	Under-	Hole	Bolt	Number of Bolts
	Diameter	Width	Thick-	Diameter	Depth	Diameter	Diameter	Circle	
	A	J	ness	F	I	H	U	B.C.	
All Dimensions in Inches									
1	4-9/16	1-21/32	9/16	3	3/32	2 -7/8	1/4	3 -3/8	6
1.5	6	1-7/8	3/4	3-7/8	3/32	3-11/16	3/8	4-13/16	8
2	7	2-3/8	3/4	4-13/16	3/32	4-5/8	1/2	5 -7/8	6
2.5	8-3/8	2-7/8	15/16	5-13/16	3/32	5-7/16	5/8	7-1/8	6
3	9-7/16	3-5/16	15/16	6-13/16	3/32	6 -7/16	5/8	8-1/8	8
3.5	11	3-13/16	1-1/8	7 -27/32	3/32	7-3/8	3/4	9-1/2	8
4	12-1/2	4-1/4	1-1/8	9-3/16	3/16	8-3/4	3/4	11	8
4.5	13-5/8	4-13/16	1-1/8	10-5/16	3/16	9-3/4	3/4	12	10
5	15-5/16	5-1/2	1-1/2	11-7/16	3/16	10-3/4	7/8	13-1/2	8
5.5	16-3/4	6	1-1/2	10-1/2	3/16	12-1/8	7/8	14-1/2	14
6	18	6-11/16	1	13-15/16	3/16	13 -3/8	7/8	15-3/4	14
7	20-3/4	7-3/8	1-1/8	15-3/4	1/4	14-5/8	1	18-1/4	16

PART NUMBERS

Part Number	Description	Part Number	Description	Part Number	Description
Size 1.0		Size 3.0		Size 5.0	
013110	DGF 1.0 FLEX HUB	013126	DGF 3.0 FLEX HUB	013142	DGF 5.0 FLEX HUB
013111	DGF 1.0 SLEEVE EB	013127	DGF 3.0 SLEEVE EB	013143	DGF 5.0 SLEEVE EB
013112	DGF 1.0 RIGID HUB EB	013128	DGF 3.0 RIGID HUB EB	013144	DGF 5.0 RIGID HUB EB
013113	DGF 1.0 HARDWARE KIT	013129	DGF 3.0 HARDWARE KIT	013145	DGF 5.0 HARDWARE KIT
Size 1.5		Size 3.5		Size 5.5	
013114	DGF 1.5 FLEX HUB	013130	DGF 3.5 FLEX HUB	013146	DGF 5.5 FLEX HUB
013115	DGF 1.5 SLEEVE EB	013131	DGF 3.5 SLEEVE EB	013147	DGF 5.5 SLEEVE EB
013116	DGF 1.5 RIGID HUB EB	013132	DGF 3.5 RIGID HUB EB	013148	DGF 5.5 RIGID HUB EB
013117	DGF 1.5 HARDWARE KIT	013133	DGF 3.5 HARDWARE KIT	013149	DGF 5.5 HARDWARE KIT
Size 2.0		Size 4.0		Size 6.0	
013118	DGF 2.0 FLEX HUB	013134	DGF 4.0 FLEX HUB	013150	DGF 6.0 FLEX HUB
013119	DGF 2.0 SLEEVE EB	013135	DGF 4.0 SLEEVE EB	013151	DGF 6.0 SLEEVE EB
013120	DGF 2.0 RIGID HUB EB	013136	DGF 4.0 RIGID HUB EB	013152	DGF 6.0 RIGID HUB EB
013121	DGF 2.0 HARDWARE KIT	013137	DGF 4.0 HARDWARE KIT		DGF 6.0 HARDWARE KIT
Size 2.5		Size 4.5		Size 7.0	
013122	DGF 2.5 FLEX HUB	013138	DGF 4.5 FLEX HUB	013154	DGF 7.0 FLEX HUB
013123	DGF 2.5 SLEEVE EB	013139	DGF 4.5 SLEEVE EB	013155	DGF 7.0 SLEEVE EB
013124	DGF 2.5 RIGID HUB EB	013140	DGF 4.5 RIGID HUB EB	013156	DGF 7.0 RIGID HUB EB
013125	DGF 2.5 HARDWARE KIT	013141	DGF 4.5 HARDWARE KIT	013157	DGF 7.0 HARDWARE KIT

Ordering Information: Standard Gear Couplings may be orders in 3 different assemblies -

- 1*. Flex-Flex (or Full Flex): To order a complete Flex-Flex coupling you need - (2) Flex Hubs [re-borable], (2) Sleeves (includes Seal), and (1) Hardware Kit.
2. Flex-Rigid: To order a complete Flex-Rigid Coupling you need - (1) Flex Hub [re-borable], (1) Sleeve (includes Seal), (1) Rigid Hub [re-borable], and (1) Hardware Kit.
3. Rigid-Rigid: To order a complete Rigid-Rigid Coupling you need - (2) Rigid Hubs [re-borable], and (1) Hardware Kit.

FEATURES/BENEFITS PAGE PT1-52	SPECIFICATION/NOMENCLATURE PAGE PT1-54	MODIFICATION/ACCESSORIES PAGE PT1-67	ENGINEERING/TECHNICAL PAGE PT1-69
----------------------------------	---	---	--------------------------------------