

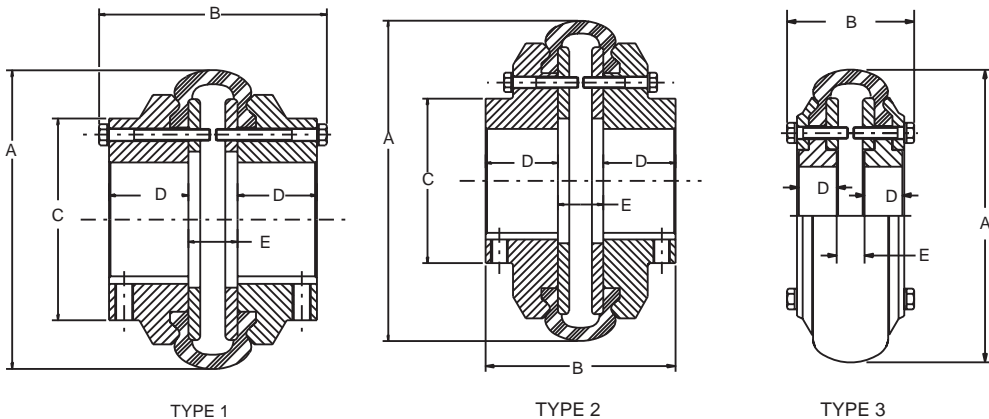

# SELECTION/DIMENSIONS



## Standard, Straight Bore



## FBX

Coupling Size	Min. Bore	Max. Bore	HP/100	Torque (In-Lbs)	Max. RPM	Dwg. Type	A	B	C	D	E	Weight (1) (Lbs.)	Inertia (2) (Lb-Ft <sup>2</sup> )
PX40FBX	1/2	1-7/16	.68	429	4500	1	4.25	3.50	2.88	1.15	.76	4.10	.05
PX50FBX	5/8	1-7/8	1.43	900	4500	1	5.25	4.44	3.14	1.51	.96	7.70	.10
PX60FBX	7/8	2-3/16	2.86	1800	4000	1	6.50	5.59	4.08	1.84	1.28	13.50	.26
PX70FBX	7/8	2-3/8	3.49	2200	3600	1	7.38	6.13	4.63	2.00	1.50	19.90	.54
PX80FBX	1-7/16	2-7/8	5.72	3605	3100	1	8.38	6.69	5.39	2.30	1.50	30.00	1.06
PX90FBX	1-7/16	3-3/8	7.15	4502	2800	1	9.25	7.69	6.09	2.70	1.53	42.40	1.96
PX100FBX	1-7/16	3-3/8 •	8.58	5402	2600	2	10.00	7.13	5.15	2.70	1.71	50.10	2.71
PX110FBX	1-1/2	3-3/4 ■	12.30	7750	2300	2	11.00	7.14	5.56	2.79	1.56	56.00	3.10
PX120FBX	1-1/2	G3-3/4	20.00	12605	2100	2	12.38	7.75	5.84	3.00	1.75	80.20	5.81

• Shallow keyway on bores of 3-1/4", 3-3/8". Key provided.

■ Shallow keyway on bores of 3-5/8", 3-3/4". Key provided.

## FBS

Coupling Size	Min. Bore	Max. Bore	HP/100	Torque (In-Lbs)	Max. RPM	Dwg. Type	A	B	D	E	Weight (1) (Lbs.)	Inertia (2) (Lb-Ft <sup>2</sup> )
PX50FBS	5/8	1-3/8	1.43	900	4500	3	5.25	2.75	.88	.53	4.10	.05
PX60FBS	7/8	1-13/16	2.86	1800	4000	3	6.50	3.36	1.00	.71	8.20	.16
PX70FBS	7/8	2-3/16	3.49	2200	3600	3	7.38	3.57	1.00	.95	11.80	.32
PX80FBS	1-7/16	2-11/16	5.72	3605	3100	3	8.38	3.57	1.25	.95	16.60	.60
PX90FBS	1-7/16	2-7/8	7.15	4502	2800	3	9.25	4.03	1.75	.33	22.60	1.00

(1) Weight of complete coupling at maximum bore.

(2) Inertia of complete coupling at maximum bore.



## Standard, Straight Bore - Part Numbers

### FBX FLANGE ASSEMBLIES

Bore (in.)	Coupling Size/Part Number								
	PX40FBX	PX50FBX	PX60FBX	PX70FBX	PX80FBX	PX90FBX	PX100FBX	PX110FBX	PX120FBX
Reborable	• 000478	• 000480	• 000481	• 000482	• 000483	• 000484	• 000485	• 000486	• 000487
Finished Bore									
Flanges									
5/8	• 000822	000575							
3/4	• 000823	000576							
7/8	• 000824	000577	000590	000606					
15/16	000825	000578	003251	003283					
1	• 000826	• 000579	000591	000607					
1-1/16	000827	000580	003252	003284					
1-1/8	• 000828	• 000581	• 000592	• 000608					
1-3/16	000829	000582	003253	003285					
1-1/4	• 000830	• 000583	• 000593	• 000609					
1-5/16	000831	000584	003254	003286					
1-3/8	• 000832	• 000585	• 000594	• 000610					
1-7/16	000833	000586	000595	003287	000619	000632	000649		
1-1/2		• 000587	• 000596	• 000611	• 000620	• 000633	000650	000666	000685
1-9/16			000597	003288	003323	003356	003402	003450	003501
1-5/8		• 000588	• 000598	• 000612	• 000621	• 000634	000651	000667	000686
1-11/16			000599	003289	003324	003357	003403	003451	003502
1-3/4		000589	• 000600	• 000613	• 000622	• 000635	• 000652	• 000668	000687
1-7/8		• 000573	• 000601	• 000614	• 000623	• 000636	• 000653	• 000669	000688
1-15/16			000602	003291	003326	003359	003405	003453	003504
2			000603	000615	000624	000637	000654	000670	000689
2-1/8			• 000604	• 000616	• 000625	• 000638	• 000655	• 000671	000690
2-3/16			000605	003293	003328	003361	003407	003455	003506
2-1/4				• 000617	• 000626	• 000639	• 000656	• 000672	000691
2-3/8				• 000618	• 000627	• 000640	• 000657	• 000673	000692
2-1/2					• 000628	• 000641	000658	000674	000693
2-5/8					000629	000642	000659	000675	000694
2-3/4					000630	000643	000660	000676	000695
2-7/8					• 000631	• 000644	• 000661	• 000677	• 000696
3						000645	000662	000678	000697
3-1/8						000646	000663	000679	000698
3-1/4						000647	000664	000680	000699
3-3/8						• 000648	• 000665	• 000681	• 000700
3-1/2								000682	000701
3-5/8								000683	000702
3-3/4								000684	000703

### FBS FLANGE ASSEMBLIES

Bore (in.)	Coupling Size/Part Number				
	PX50FBS	PX60FBS	PX70FBS	PX80FBS	PX90FBS
Reborable	• 009199	• 009214	• 009215	• 009223	• 009230

(1) Standard natural rubber element Part Numbers on Page PT1-22

- Stocked flange assemblies

Complete coupling consists of (2) FBX or FBS flange assemblies, and (1) element.

FEATURES/BENEFITS PAGE PT1-14	EASY SELECTION PAGE PT1-5	MODIFICATION/ACCESSORIES PAGE PT1-67	ENGINEERING/TECHNICAL PAGE PT1-69
----------------------------------	------------------------------	---	--------------------------------------



# SELECTION/DIMENSIONS



## Standard, TAPER-LOCK

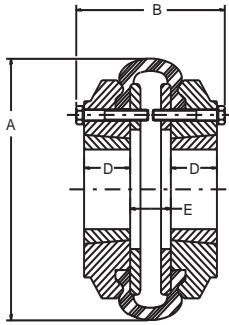

PX40 STANDARD COUPLING  
TYPE H TAPER-LOCK

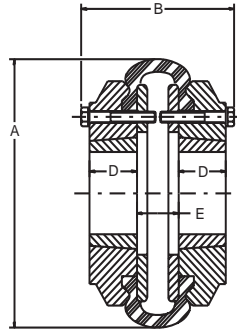

PX40 STANDARD COUPLING  
TYPE F TAPER-LOCK

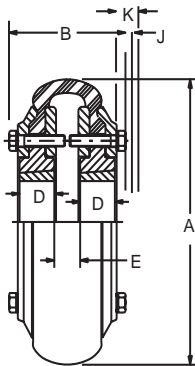

TYPE HF

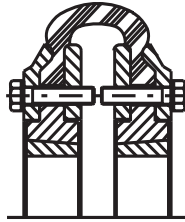

TYPE H

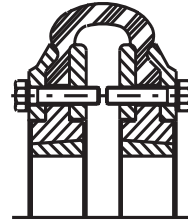

TYPE F

### PX-50-120 PARA-FLEX TAPER-LOCK COUPLINGS

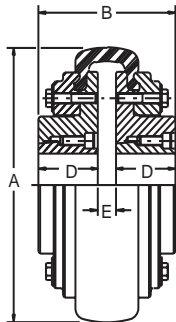

TYPE HF

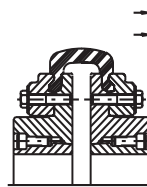

TYPE H-H

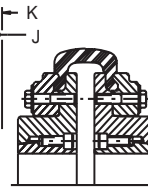

TYPE F-F

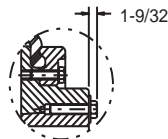

PX280 & 320 ONLY

### PX-140-320 PARA-FLEX TAPER-LOCK COUPLINGS

<p>FEATURES/BENEFITS PAGE PT1-14</p>	<p>EASY SELECTION PAGE PT1-5</p>	<p>MODIFICATION/ACCESSORIES PAGE PT1-67</p>	<p>ENGINEERING/TECHNICAL PAGE PT1-69</p>
--	--------------------------------------	---	--



## Standard, TAPER-LOCK

Coupling Size	Max. Bore	HP/100	Torque (In-Lbs)	Max. RPM	A	B	D	E	J (1)	K (2)	Weight (Lbs.) (3)	Inertia (Lb-Ft <sup>2</sup> ) (4)
PX40TL	1	.68	429	4500	4.25	3.00	0.88	0.77	0.63	0.75	4.20	0.05
PX50TL	1-1/8	1.43	900	4500	5.25	2.75	0.88	0.53	0.63	0.75	4.70	0.07
PX60TL	1-7/16	2.86	1800	4000	6.50	3.34	1.00	0.72	0.81	1.06	9.20	0.21
PX70TL	1-11/16	3.49	2200	3600	7.38	3.56	1.00	0.95	0.81	1.06	13.00	0.30
PX80TL	2-1/8	5.72	3605	3100	8.38	3.75	1.25	0.77	0.94	1.38	19.60	0.73
PX90TL	2-11/16	7.15	4502	2800	9.25	4.03	1.75	0.33	1.00	1.63	28.80	1.30
PX100TL	2-11/16	8.58	5402	2600	10.00	4.22	1.75	0.52	1.00	1.63	38.00	2.20
PX110TL	2-11/16	12.30	7750	2300	11.00	4.53	1.75	0.47	1.00	1.63	52.10	3.70
PX120TL	3-1/4	20.00	12605	2100	12.38	5.03	2.00	0.44	1.19	2.06	74.40	6.60
PX140TL	3-15/16	44.00	27590	1840	14.13	7.81	3.50	0.81	1.31	2.69	156.00	18.70
PX160TL	4-7/16	60.00	37800	1560	16.63	9.19	4.00	1.19	1.63	3.38	243.00	33.70
PX200TL	4-15/16	131.00	82500	1300	20.00	10.31	4.50	1.31	1.94	4.06	417.00	101.00
PX240TL	5	240.00	151200	1080	24.13	11.91	5.00	1.91	2.31	4.81	682.00	231.00
PX280TL	7	480.00	302200	910	28.50	15.97	6.00	2.22	1.63	4.38	1148.00	544.00
PX320TL	8	719.00	453000	810	32.50	16.31	6.50	2.06	1.63	4.38	1640.00	1077.00

- Notes:**
- (1) Space required to tighten bushing with shortened hex key.
  - (2) Space required to loosen bushing with shortened hex key.
  - (3) Weight of complete coupling with bushing.
  - (4) Inertia of complete coupling with bushing.



# SELECTION/DIMENSIONS



## Standard, TAPER-LOCK Part Numbers

### TAPER-LOCK FLANGE ASSEMBLIES

Coupling Size	Flange Assembly Part No.		TAPER-LOCK Bushing Size
	Type H	Type F	
PX40	000849	000848	1008
PX50	010601	*	1108
PX60	010602	*	1310
PX70	010603	*	1610
PX80	010604	*	2012
PX90	010605	*	2517
PX100	010606	*	2517
PX110	010607	*	2517
PX120	010608	*	3020
PX140	011134	011154	3535
PX160	011137	011157	4040
PX200	011140	011160	4545
PX240	011144	011164	5050
PX280	011455	011456	7060
PX320	011472	011471	8065

\* PX50-PX120 have a reversible flange for type H or F mount

Complete coupling consists of (2) TAPER-LOCK Flange Assemblies, and (1) element.

### STANDARD NATURAL RUBBER ELEMENTS †

Coupling Size	Flexible Element Part No.
PX40	011529
PX50	011105
PX60	011106
PX70	011107
PX80	011108
PX90	011109
PX100	011110
PX110	011111
PX120	011112
PX140	011114
PX160	011117
PX200	011120
PX240	011124
PX280	011457
PX320	011463

† See page PT1-67 for optional elements





## Standard, TAPER-LOCK Part Numbers

### METRIC PARA-FLEX TAPER-LOCK FLANGE ASSEMBLIES

Coupling Size	Flange Assembly Part No.		Taper-Lock Bushing Size
	Type H	Type F	
PXM40	013095	013096	1008
PXM50	013040	013041	1210
PXM60	013043	013042	1610
PXM70	013044	■	1610
PXM80	013045	■	2012
PXM90	013046	■	2517 *
PXM100	013047	■	2517 *
PXM110	013048	■	2517 *
PXM120	013049	■	3020



■ PXM70 - PXM120 have a reversible flange for type H or F mount.

\* Hard metric bushing required

**Note:** For TAPER-LOCK designs, TAPER-LOCK bushings must be ordered separately.



# SELECTION/DIMENSIONS



## Spacer, Straight Bore

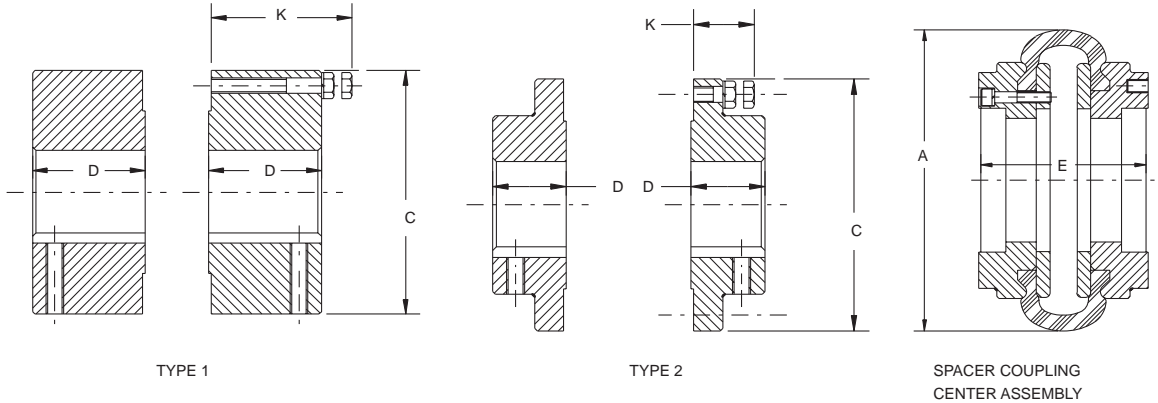

TYPE 1

TYPE 2

SPACER COUPLING  
CENTER ASSEMBLY

## SPACER SHAFT HUBS

Coupling Size	Min. Bore	Max. Bore	HP/100	Torque (In-Lbs)	Max. RPM	Dwg. Type	C	D	K (1)	Weight (Lbs.) (2)	Inertia (Lb. Ft. <sup>2</sup> )
PS40FBX	1/2	1-7/16	0.68	429	4500	1	2.88	1.13	1.75	1.30	0.01
PS50FBX	5/8	1-7/8	1.43	900	4500	1	3.81	1.41	2.25	3.20	0.05
PS60FBX	2	2-3/16	2.86	1800	4000	1	4.45	1.28	2.13	4.90	0.11
PS60FBS	7/8	1-15/16	2.86	1800	4000	1	4.45	1.22	2.50	4.00	0.08
PS70FBX	2	2-3/8	3.49	2200	3600	1	5.02	1.78	2.63	7.10	0.18
PS70FBS	7/8	1-7/8	3.49	2200	3600	2	5.02	1.22	1.25	2.90	0.06
PS80FBX	2-1/8	3-3/8	5.72	3605	3100	1	6.02	2.53	3.38	12.90	0.53
PS80FBS	1-7/16	2-1/8	5.72	3605	3100	2	6.02	1.50	1.50	5.30	0.16
PS90FBX	2-1/8	3-3/8	7.15	4502	2800	1	6.02	2.53	3.38	12.90	0.53
PS90FBS	1-7/16	2-1/8	7.15	4502	2800	2	6.02	1.50	1.50	5.30	0.16
PS100FBX	2-5/8	3-3/4	8.58	5402	2600	1	6.77	2.53	3.50	16.50	0.85
PS100FBS	1-7/16	2-1/2	8.58	5402	2600	2	6.77	1.88	1.50	7.30	0.26
PS110FBX	2-5/8	3-3/4	12.3	7750	2300	1	6.77	2.53	3.50	16.50	0.85
PS110FBS	1-7/16	2-1/2	12.3	7750	2300	2	6.77	1.88	1.50	7.30	0.26
PS120FBX	2-5/8	3-3/4	20.0	12605	2100	2	8.27	2.81	1.88	14.40	0.50
PS120FBS	1-1/2	2-1/2	20.0	12605	2100	2	8.27	1.88	1.88	14.60	0.51

## SPACER CENTER ASSEMBLIES

Coupling Size	A	E		Weight (Lbs.) (3)	Weight Adder (4)	Inertia (Lb.Ft. <sup>2</sup> ) (5)	Inertia Adder (6)
		Min.	Max.				
PS40	4.25	2.75	5.75	4.00	0.50	0.04	0.01
PS50	5.25	2.88	7.33	6.90	1.28	0.10	0.02
PS60	6.50	3.38	7.33	9.50	1.70	0.28	0.03
PS70	7.38	3.50	7.50	12.20	2.10	0.50	0.07
PS80	8.38	3.50	10.00	16.90	2.90	0.89	0.22
PS90	9.25	3.50	10.00	21.10	2.90	1.40	0.22
PS100	10.00	3.50	10.00	23.60	3.87	2.10	0.28
PS110	11.00	3.50	10.00	41.00	3.87	3.30	0.28
PS120	12.38	4.50	10.00	56.40	5.86	7.30	0.76

(1) Screw clearance required to remove center assembly

(2) Hub weight at maximum bore

(3) Center assembly weight at minimum length

(4) Weight adder per inch length

(5) Center assembly inertia at minimum length

(6) Inertia adder per inch length



## Spacer, Straight Bore Shaft Hub - Part Numbers (1)

Bore (in.)	Coupling Size/Part Number													
	PS40		PS50		PS60		PS70		PS80/90		PS100/110		PS120	
	FBX	FBX	FBS	FBX	FBS	FBX	FBS	FBX	FBS	FBX	FBS	FBX	FBS	FBX
Reborable	• 000479	• 000490	• 000492	• 000491	• 000494	000493	• 000496	• 000495	• 000498	• 000497	• 000500	• 000499		
5/8	• 000836	000704												
3/4	• 000837	000705												
7/8	• 000838	000706	000719		000739									
15/16	000839	000707												
1	• 000840	• 000708	000720		000740									
1-1/16	000841	000709												
1-1/8	• 000842	• 000710	• 000721		• 000741									
1-3/16	000843	000711												
1-1/4	• 000844	• 000712	• 000722		• 000742									
1-5/16	000845	000713												
1-3/8	• 000846	• 000714	• 000723		• 000743									
1-7/16	000847	000715	000724				000759		000776					
1-1/2		• 000716	• 000725		• 000744		• 000760		000777			000796		
1-9/16			000726											
1-5/8		• 000717	• 000727		• 000745		• 000761		000778			000797		
1-11/16			000728											
1-3/4		000718	• 000729		• 000746		• 000762		• 000779			• 000798		
1-7/8		• 000574	• 000730		• 000747		• 000763		• 000780			• 000799		
1-15/16			000731											
2				000732		000735	000764		000781			000800		
2-1/8				• 000733		• 000736	000765	• 000748	• 000782			• 000801		
2-3/16				000734										
2-1/4						• 000737		• 000749	• 000783			• 000802		
2-3/8						• 000738		• 000750	• 000784			• 000803		
2-1/2								• 000751	• 000785			• 000804		
2-5/8								000752			000766		000786	
2-3/4								000753			000767		000787	
2-7/8								• 000754			• 000768		• 000788	
3								000755			000769		000789	
3-1/8								000756			000770		000790	
3-1/4								000757			000771		000791	
3-3/8								• 000758			• 000772		• 000792	
3-1/2											000773		000793	
3-5/8											000774		000794	
3-3/4											000775		000795	

• Stocked shaft hubs

(1) See page PT1-27 for spacer center assembly part numbers.

Complete coupling consists of:

(2) Shaft Hubs, TAPER-LOCK or Straight Bore

(1) Spacer Center Assembly

NOTE: Standard Bore Tolerances: Straight bore couplings from PX40 - PX120 are furnished with clearance fit.

PX140 - PX320 are furnished with interference fit.



# SELECTION/DIMENSIONS



## Spacer, TAPER-LOCK

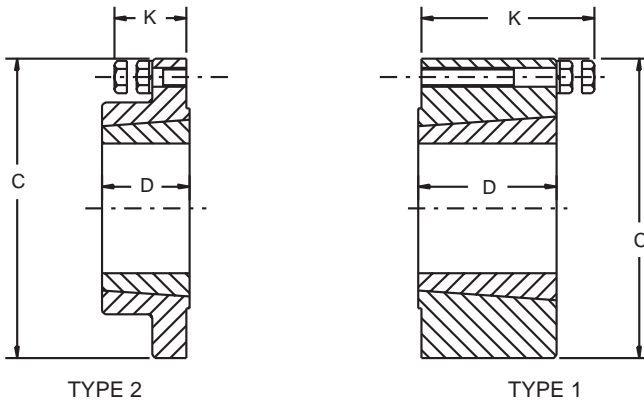

TYPE 2

TYPE 1

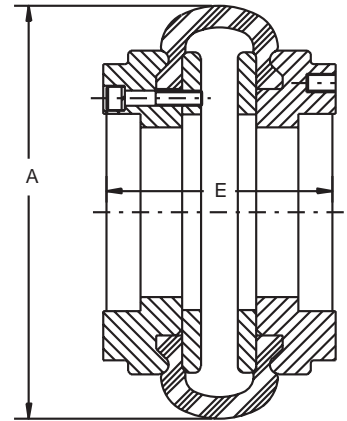
SPACER COUPLING  
CENTER ASSEMBLY

### TAPER-LOCK SPACER SHAFT HUBS

Coupling Size	Max. Bore	HP/100	Torque (In-Lbs)	Max. RPM	Dwg. Type	C	D	K(1)	Weight (Lbs) (2)	Inertia (Lb.Ft. <sup>2</sup> )
PS40TL	1	.68	429	4500	1	2.88	0.88	1.75	1.10	0.01
PS50TL	1-1/4	1.43	900	4500	2	3.81	1.00	1.00	1.80	0.02
PS60TL	1-11/16	2.86	1800	4000	2	4.44	1.00	1.00	2.40	0.03
PS70TL	2-1/8	3.49	2200	3600	2	5.00	1.25	1.00	4.00	0.07
PS80TL	2-11/16	5.72	3605	3100	2	6.00	1.75	1.25	7.70	0.22
PS90TL	2-11/16	7.15	4502	2800	2	6.00	1.75	1.25	7.70	0.22
PS100TL	2-11/16	8.58	5402	2600	2	6.75	1.75	1.25	9.00	0.28
PS110TL	2-11/16	12.30	7750	2300	2	6.75	1.75	1.25	9.00	0.28
PS120TL	3-1/4	20.00	12605	2100	2	8.25	2.00	1.50	16.60	0.76
PS140TL	3-15/16	44.00	27590	1840	1	7.69	3.50	4.50	37.00	2.20
PS160TL	4-7/16	60.00	37800	1560	1	8.63	4.00	5.00	55.00	3.90
PS200TL	4-15/16	131.00	82500	1300	1	10.00	4.50	5.50	87.40	8.00

### SPACER CENTER ASSEMBLIES

Coupling Size	A	E		Weight (Lbs.) (3)	Weight Adder (4)	Inertia (Lb. Ft.2) (5)	Inertia Adder (6)
		Min.	Max.				
PS40	4.25	2.75	5.75	4.00	.50	0.04	0.01
PS50	5.25	2.88	7.33	6.90	1.28	0.10	0.02
PS60	6.50	3.38	7.33	9.50	1.70	0.28	0.03
PS70	7.38	3.50	7.50	12.20	2.10	0.50	0.07
PS80	8.38	3.50	10.00	16.90	2.90	1.89	0.22
PS90	9.25	3.50	10.00	21.10	2.90	1.40	0.22
PS100	10.00	3.50	10.00	23.60	3.87	2.10	0.28
PS110	11.00	3.50	10.00	41.00	3.87	3.30	0.28
PS120	12.38	4.50	10.00	56.40	5.86	7.30	0.76
PS140	14.13	6.44	13.00	115.00	4.49	18.70	0.80
PS160	16.63	8.06	11.44	216.00	5.58	33.70	0.90
PS200	20.00	9.94	12.88	290.00	7.65	101.00	1.60

- (1) Screw clearance required to remove center assembly  
 (2) Hub weight includes bushing at max. bore  
 (3) Center assembly weight at minimum length

- (4) Weight adder per inch length  
 (5) Center assembly inertia at minimum length  
 (6) Inertia added per inch length



## Spacer, TAPER-LOCK Shaft - Hubs Part Numbers

Coupling Size	Shaft Hub Part No.	TAPER-LOCK Bushing Size
PS40	000850	1008
PS50	011620	1210
PS60	011621	1610
PS70	011622	2010
PS80	011623	2517
PS90	011623	2517
PS100	011624	2517
PS110	011624	2517
PS120	011625	3020
PS140	011626	3535
PS160	011627	4040
PS200	011628	4545



For complete listing of part numbers for all BSE lengths, see page PT1-28 and PT1-29

**Complete coupling consists of: (2) shaft hubs, TAPER-LOCK straight bore, and (1) Spacer center assy**

**NOTE: For TAPER-LOCK designs, TAPER-LOCK bushings must be ordered separately**



# SELECTION/DIMENSIONS



## PARA-FLEX

### SPACER CENTER ASSEMBLY PART NUMBERS

B.S.E.	PS40	PS50	PS60	PS70	PS80	PS90	PS100	PS110	PS120	PS140	PS160	PS200
2-7/8		011121										
3		011125										
3-1/8		011132										
3-1/4		011145										
3-3/8		011152	010723									
3-1/2	• 000854	011565	011567	N 011569	N 011571	N 011564	N 011579	N 011580				
3-5/8		011720	011726	011740	011775							
3-11/16								011890				
3-3/4		011721	011727	011741	011776	011589		011891				
3-7/8		011722	011728	011742	011777			011892				
4		011723	011729	• 011743	• 011778	• 011555		• 011893				
4-1/8		011724	011730	011744	011779	011810	011850	011894				
4-1/4		011725	011731	011745	011780	011811	011851	011895				
4-3/8		011582	011732	011746	011781	011812	011852	011896				
4-1/2			011583	011584		011586	011587	011897	011581			
4-5/8			011733	011747	011782	011813	011853	011898				
4-3/4			011734	011748	011783	011814	011854	011899	011935			
4-7/8				011749	011784	011815	011855	011900	011936			
5	• 000857	• 012767	• 012765	• 011750	• 011785	• 011816	• 011700	• 011705	• 011937			
5-1/8				011751	011786	011817	011856	011901	011938			
5-1/4				011752	011787	011818	011857	011902	011939			
5-5/16							011847					
5-3/8				011753	011788	011819	011858	011903	011940			
5-1/2				011754	011789	011820	011859	011904	011941			
5-5/8				011755	011790	011821	011860	011905	011942			
5-3/4	000858	000859	000861	011756	011791	011822	011861	011906	011943			
5-7/8				011757	011792	011823	011862	011907	011944			
6				• 011758	• 011793	• 011824	• 011701	• 011706	• 011710			
6-1/16												
6-1/8				011602	011794	011825	011863	011908	011945			
6-1/4				011759	011795	011826	011864	011909	011946			
6-5/16												
6-3/8				011760	011796	011827	011865	011910	011947			
6-7/16										010539		
6-1/2				011761	011797	011828	011866	011911	011948	010547		
6-5/8				011762	011798	011829	011867	011912	011949	010548		
6-3/4				011763	011799	011830	011868	011913	011950	010549		
6-7/8				011764	011604	011606	011869	011914	011951	010550		
7			• 012766	• 011765	• 011800	• 011831	• 011702	• 011707	• 011711	• 010551		
7-1/8				011766	011801	011832	011870	011915	011952	010552		
7-1/4				011767	011802	011833	011871	011916	011953	010553		
7-1/3		000860	000862		012289				012291	012290		
7-3/8				011768	011803	011834	011872	011917	011954	010554		
7-1/2				• 011603	• 011804	011835	011873	011918	011955	010555		
7-5/8					011805	011836	011874	011919	011956	010556		
7-3/4					011806	011837	011875	011920	011957	010975		
7-7/8					011807	011838	011876	011921	011958	010976		

• Stock Center Assemblies

FEATURES/BENEFITS PAGE PT1-14	EASY SELECTION PAGE PT1-5	MODIFICATION/ACCESSORIES PAGE PT1-67	ENGINEERING/TECHNICAL PAGE PT1-69
----------------------------------	------------------------------	---	--------------------------------------



## PARA-FLEX

### SPACER CENTER ASSEMBLY PART NUMBERS

B.S.E.	PS40	PS50	PS60	PS70	PS80	PS90	PS100	PS110	PS120	PS140	PS160	PS200
Semi Fin	000851	010997	010998	011012	011000	011001	011002	011005	011006	011113	011115	011119
8					011605	011839	011703	011708	011712	010977		
8-1/16											010595	
8-1/8					009420	011840	011877	011922	011959	010978	010567	
8-3/16					009419							
8-1/4					009421	011841	011878	011923	011960	010979	010568	
8-3/8					009422	011842	011879	011924	011961	010980	010569	
8-1/2					009423	011607	011880	011925	011962	010981	010570	
8-5/8					009424			011926	011963	010982	010571	
8-3/4					009425			011927	011964	010983	010572	
8-7/8					009426			011928	011965	010984	010573	
9					009427			011709	011713	010985	010574	
9-1/8					009428			011929	011966	010986	010575	
9-3/16								011930	011967			
9-1/4					009429				012023	010987	010576	
9-3/8					009430				012024	010988	010577	
9-1/2					009431				012025	010989	010578	
9-5/8					009432				012026	010990	010579	
9-3/4					009433				012027	010991	• 010580	
9-7/8					009434				012028	010992	• 010581	
9-15/16												010699
10					• 009435	• 000863	000864	• 000865	• 012029	• 010993	• 010582	• 010675
10-1/8										010994	010583	010676
10-1/4										010995	010584	010677
10-5/16										010996		
10-3/8										009436	010585	010678
10-1/2										009437	010586	010679
10-5/8										009438	010587	010680
10-3/4										009439	010588	010681
10-7/8										009440	010589	010682
11										009441	010590	010683
11-1/8										009442	010591	010684
11-1/4										009443	010592	010685
11-3/8										009444	010593	010686
11-7/16											010594	
11-1/2										009445		010687
11-5/8										009446		010688
11-3/4										009447		010689
11-7/8										009448		010690
12										009449		010691
12-1/8										009450		010692
12-1/4										009451		010693
12-3/8										009452		010694
12-1/2										009453		010695
12-5/8										009454		010696
12-3/4										009455		010697
12-7/8										009456		010698
13										009457		

• Stock Center Assemblies

FEATURES/BENEFITS PAGE PT1-14	EASY SELECTION PAGE PT1-5	MODIFICATION/ACCESSORIES PAGE PT1-67	ENGINEERING/TECHNICAL PAGE PT1-69
----------------------------------	------------------------------	---	--------------------------------------



# SELECTION/DIMENSIONS



## Bored to Size, Type BBS

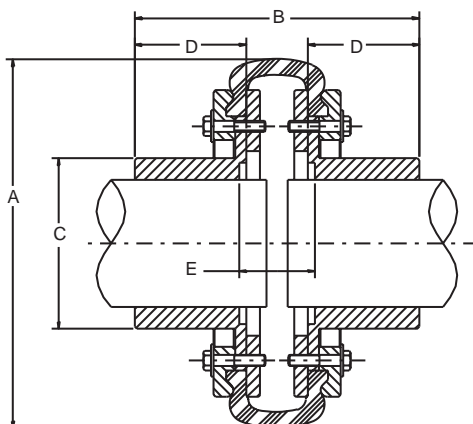

### PX60 THRU PX320 TYPE BBS COUPLINGS

Coupling Size	Min. Bore	Max. Bore	HP/100	Torque (In-Lbs)	Max. RPM	A	B	C	D	E	Weight (1) (Lbs.)	Inertia (2) (Lb-Ft <sup>2</sup> )
PX60BBS	none	1-1/2	2.86	1,800	4000	6.50	4.28	2.38	1.50	1.28	8.8	.21
PX70BBS	none	2-1/8	3.49	2,200	3600	7.38	5.00	2.94	1.75	1.50	12.8	.32
PX80BBS	none	2-9/16	5.72	3,605	3100	8.38	5.50	3.69	2.00	1.50	18.4	.79
PX90BBS	none	2-3/4	7.15	4,502	2800	9.25	6.03	4.13	2.25	1.53	25.6	1.4
PX100BBS	none	3-1/4	8.58	5,402	2600	10.00	6.97	4.94	2.63	1.72	36.4	2.5
PX110BBS	none	3-15/16	12.30	7,750	2300	11.00	7.56	5.44	3.00	1.56	47.3	4.2
PX120BBS	none	4	20.00	12,605	2100	12.38	8.25	5.81	3.25	1.75	68.4	7.0
PX140BBS	2-1/4	4-1/2	44.00	27,590	1840	14.13	9.81	7.00	3.88	2.44	127.2	16.4
PX160BBS	2-1/2	6	60.00	37,800	1560	16.63	12.94	8.50	5.13	3.06	210.8	39.6
PX200BBS	2-7/8	6-3/4	131.00	82,500	1300	20.00	15.56	9.38	6.13	3.75	333.5	76.9
PX240BBS	4	7-1/2	240.00	151,200	1080	24.13	14.16	10.00	5.13	4.34	481.0	188.1
PX280BBS	4-7/16	9	480.00	302,200	910	28.50	18.47	12.00	7.13	4.66	802.0	440.8
PX320BBS	5-1/2	11	719.00	453,000	810	32.50	20.75	14.00	8.13	4.94	1074.0	709.6

(1) Weight of complete coupling at maximum bore

(2) Inertia of complete coupling at maximum bore



## Bored to Size, Type BBS



### PX60BBS - PX320BBS PART NUMBERS

Coupling Size	BS Flange Assemblies Rough Bore (2 Req'd)	Standard Element (1 Req'd)
PX60BBS	010300	011106
PX70BBS	010301	011107
PX80BBS	010302	011108
PX90BBS	010303	011109
PX100BBS	010304	011110
PX110BBS	010305	011111
PX120BBS	010306	011112
PX140BBS	010530	011114
PX160BBS	010531	011117
PX200BBS	010532	011120
PX240BBS	010533	011124
PX280BBS	010528	011457
PX320BBS	010529	011463

When bored to size, the PX60 through PX120 BBS sizes are furnished with clearance fit, standard keyway and two-set screws. PX140 and larger sizes are furnished as interference fit with standard keyway and no setscrew.

**Complete coupling consists of: (2) BS Flange Assemblies and (1) Standard Element.**



# SELECTION/DIMENSIONS



## Mill Motor, Type TBS\*

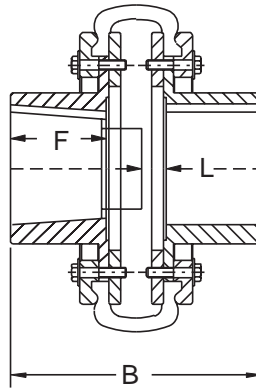

Size	For Mill Motor Size	Min. Bore	Max. Bore	HP/100	Torque (In-Lbs)	Max. RPM	B	F	L	Weight(1) (Lbs.)	Inertia(2) (Lb-Ft <sup>2</sup> )	
PX60TBS	602,802*	none	1-1/2	2.86	1,800	4000	5.78	3.00	0.34	10.1	0.21	
PX70TBS	603	none	2-1/8	3.49	2,200	3600	6.75	3.50	0.50	16.1	0.32	
	802B,802C						6.25	3.00	0.56			
PX80TBS	603,803	none	2-9/16	5.72	3,605	3100	7.00	3.50	0.50	23.2	0.79	
	604804						7.00	3.50	0.50			
PX90TBS	804	none	2-3/4	7.15	4,502	2800	7.28	3.50	0.53	29.9	1.4	
PX100TBS	804	none	3-1/4	8.58	5,402	2600	7.84	3.50	0.72	44.4	2.5	
PX110TBS	606,806	none	3-15/16	12.30	7,750	2300	8.56	4.00	0.59	62.3	4.2	
	608						9.06	4.50	0.16			
PX120TBS	608,806	none	4	20.00	12,605	2100	9.00	4.00	0.63	81.4	7.0	
	608,808						9.50	4.50	0.50			
PX140TBS	808	2-1/4	4-1/2	44.00	27,590	1840	10.63	4.69	1.19	136.2	16.4	
							610-810	10.63	4.69			1.06
							612	11.06	5.13			0.94
PX160TBS	810	2-1/2	6	60.00	37,800	1560	12.50	4.69	1.69	227.8	39.6	
							612-812	12.94	5.13			1.56
							614	12.94	5.13			1.44
PX200TBS	812	2-7/8	6-3/4	131.00	82,500	1300	14.63	5.19	2.19	344.5	76.9	
							614-814	14.63	5.19			2.06
							616-816	15.13	5.69			1.94
							618-818	15.56	6.13			2.38
PX240TBS	818	4	7-1/2	240.00	151,200	1080	15.22	6.19	2.97	519	188.1	
							620	15.91	6.88			2.53
PX280TBS	622	5-1/4	9	480.00	302,200	910	18.78	7.44	2.22	836	440.8	
							624	20.78	9.44			2.22

◆ Refer to page PT1-30 for additional envelope information

\* 1-1/4" per foot taper on diameter

FEATURES/BENEFITS  
PAGE PT1-14

EASY SELECTION  
PAGE PT1-5

MODIFICATION/ACCESSORIES  
PAGE PT1-67

ENGINEERING/TECHNICAL  
PAGE PT1-69



## Mill Motor, Type TBS\*

### PX60 - PX280 TBS PART NUMBERS

Coupling Size	For Mill Motor Size	TS Flange Assy (1) Req'd +	Std. Element (1) Req'd	BS Flange Assy (1) Req'd
PX60TBS	602,802*	010471	011106	See Page PT1-30
PX70TBS	603	010472	011107	
	802B,802C	010473		
PX80TBS	603,803	010474	011108	
	604,804			
PX90TBS	804	010475	011109	
PX100TBS	804	010476	011110	
PX110TBS	606,806	010477	011111	
	608	010478		
PX120TBS	606,806	010479	011112	
	608,808	010480		
PX140TBS	608,808	008980	011114	
	610,810	008981		
	612,812	008982		
PX160TBS	610,810	008983	011117	
	612,812	008984		
	614	008985		
PX200TBS	612,812	008986	011120	
	614,814	008987		
	616,816	008988		
	618,818	008989		
PX240TBS	818	008990	011124	
	620	008991		
PX280TBS	622	008992	011457	
	624	008993		

Coupling Size	TS Flange Assy Rough Bore
PX60TBS	010510
PX70TBS	010511
PX80TBS	010512
PX90TBS	010513
PX100TBS	010514
PX110TBS	010515
PX120TBS	010516
PX140TBS	010524
PX160TBS	010531
PX200TBS	010532
PX240TBS	010525
PX280TBS	010526

Complete coupling consists of: (1) TS Flange Assembly, (1) BS Flange Assembly, and (1) Standard Element.

\* Key furnished for shallow keyways.

+ Part numbers are finished bore flanges to fit mill motor sizes listed.



# SELECTION/DIMENSIONS



## Floating Shaft, Type BBPS

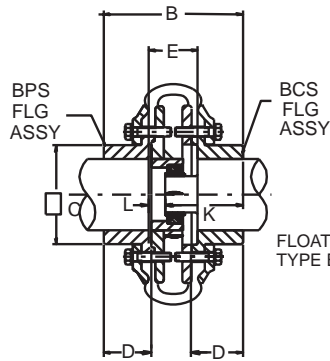

PX60 -120 BBPS

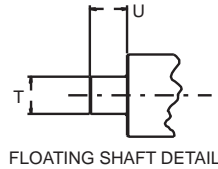
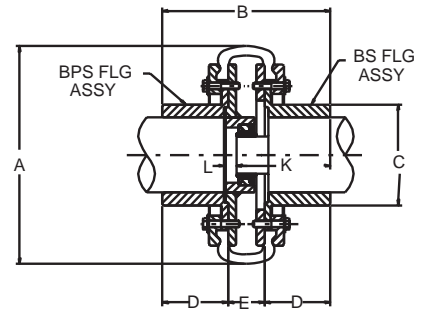
FLOATING SHAFT  
TYPE BBPS

PX140-320 BBPS

Size	Min. Bore	Max. Bore	HP/100	Torque (In-Lbs)	Max RPM	A	B	C	D	E	K	L	T	U	Weight (Lbs)	Inertia (Lb-Ft <sup>2</sup> )
PX60BBPS	none	1-1/2	2.86	1,800	4000	6.50	4.28	2.38	1.50	1.78	2.45	0.58	.624/.6225	1.28	9.8	0.21
PX70BBPS	none	2-1/8	3.49	2,200	3600	7.38	5.00	2.94	1.75	2.06	3.05	0.48	.999/.9975	1.58	14.6	0.32
PX80BBPS	none	2-9/16	5.72	3,605	3100	8.38	5.50	3.69	2.00	2.00	3.30	0.45	.999/.9975	1.58	26.9	0.79
PX90BBPS	none	2-3/4	7.15	4,502	2800	9.25	6.03	4.13	2.25	2.09	3.67	0.39	1.249/1.2475	1.70	29.0	1.4
PX100BBPS	none	3-1/4	5.85	5,402	2600	10.00	6.97	4.94	2.63	2.16	4.13	0.44	1.249/1.2475	1.72	40.1	2.5
PX110BBPS	none	3-15/16	12.30	7,750	2300	11.00	7.56	5.44	3.00	2.06	4.44	0.38	1.249/1.2475	1.69	51.0	4.2
PX120BBPS	none	4	20	12,605	2100	12.38	8.25	5.81	3.25	2.44	4.89	0.45	1.499/1.497	1.98	75.7	7.0
PX140BBPS	2-1/4	4-1/2	44	27,590	1840	14.13	9.19	7.00	3.88	2.44	5.69	0.44	1.499/1.497	2.00	140.2	16.4
PX160BBPS	2-1/2	6	60	37,800	1560	16.63	12.94	8.50	5.13	3.06	7.25	0.75	1.499/1.497	2.94	230.8	39.6
PX200BBPS	2-7/8	6-3/4	131	82,500	1300	20.00	15.56	9.38	6.13	3.69	8.78	0.84	1.999/1.997	2.84	364.5	76.9
PX240BBPS	4	7-1/2	240	151,200	1080	24.13	14.16	10.00	5.13	4.28	8.06	1.16	1.999/1.997	3.12	529.0	188.1
PX280BBPS	4-7/16	9	480	302,200	910	28.50	18.47	12.00	7.13	4.59	10.22	1.31	1.999/1.997	3.28	877.0	440.8
PX320BBPS	5-1/2	11	719	453,000	810	32.50	20.75	14.00	8.13	4.88	11.38	1.44	1.999/1.997	3.44	1181.0	709.6

### PX60BBPS - PX320BBPS PART NUMBERS

Coupling Size	BCS Flange Assy (1) Req'd	BPS Flange Assy (1) Req'd	Std Element (1) Req'd
PX60BBPS	010658	010657	011106
PX70BBPS	010660	010659	011107
PX80BBPS	010189	010190	011108
PX90BBPS	010191	010192	011109
PX100BBPS	010193	010194	011110
PX110BBPS	010599	010598	011111
PX120BBPS	010195	010196	011112
Coupling Size	BS Flange Assy (1) Req'd	BPS Flange Assy (1) Req'd	Std Element (1) Req'd
PX140BBPS	010530	011714	011114
PX160BBPS	010531	011715	011117
PX200BBPS	010532	011716	011120
PX240BBPS	010533	011717	011124
PX280BBPS	010528	011718	011457
PX320BBPS	010529	011719	011463

Complete coupling consists of: (1) BCS or BS Flange Assembly (depending on size of coupling), (1) BPS Flange Assembly, and (1) Standard Element.

BCS Flange Assembly consists of:

1. External Clamp Ring
2. Internal Clamp Ring
3. BCS Flange

BPS Flange Assembly consists of:

1. External Clamp Ring
2. Piloted Internal Clamp Ring
  - a. Includes floating shaft bearing assembly
3. BS Flange