

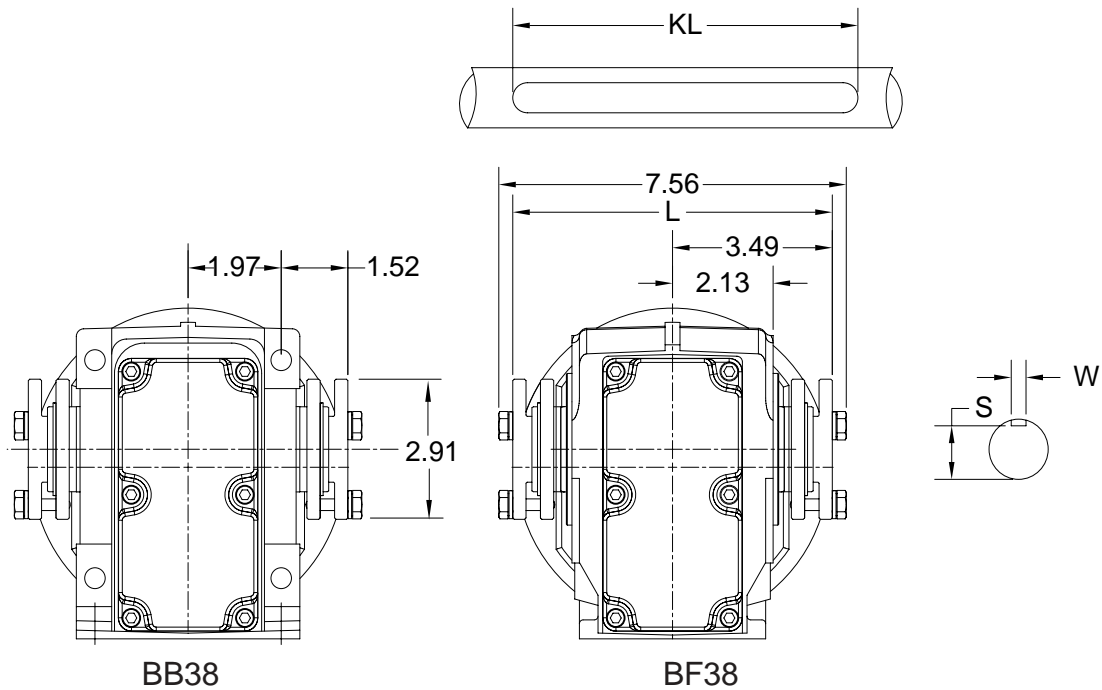

SELECTION/DIMENSIONS

RIGHT ANGLE HELICAL BEVEL REDUCER (RHB) Twin Tapered Bushing

SIZE: B_38



Part Number	RHB Size 38	Bore	Weight (lbs)	L	Part Number	RHB Size 38	Bore	Weight (lbs)	L	Shaft Keyseat			
										W	S	KL (3)	
093105	Standard (1)	1.3750"	2.0	6.97"	---	---	---	---	---	0.313	1.201	7.00"	
093106	Standard	1.3125"	2.0		---	---	---	---	---	---	0.313		1.137
093107	Standard	1.2500"	2.4		---	---	---	---	---	---	0.250		1.112
093108	Standard	1.1875"	2.0		093115	Short Shaft (2)	1.1875"	2.0	5.15"	---	0.250		1.049
093109	Standard	1.1250"	2.0		093116	Short Shaft	1.1250"	2.0			0.250		0.986
093110	Standard	1.0000"	2.0		093117	Short Shaft	1.0000"	2.0			0.250		0.859
093111	Standard	35 MM	2.0		---	---	---	---	---	---	10 mm		30 mm
093112	Standard	32 MM	2.0		---	---	---	---	---	---	10 mm		27 mm
093113	Standard	30 MM	2.0		093118	Short Shaft	30 MM	2.0	5.15"	---	8 mm		26 mm
093114	Standard	25 MM	2.0		093119	Short Shaft	25 MM	2.0	5.15"	---	8 mm		21 mm

- (1) - Standard Shaft Bushing Kit includes two standard bushings with two back-up plates and snap rings; hardware, and key.
- (2) - Short Shaft Bushing Kit includes one standard bushing, one long bushing with insertable wedge; two back-up plates with snap rings; hardware and key.
This is an optional bushing for after market short shaft mounting.
- (3) - Standard key provided for Short Shaft Kit. Key will overhang customer shaft within bore.
- (---) - Bore Size not available.

Shaded Bore Sizes are Standard Non-Stock.

MOUNTING POSITIONS PAGE RHB-7	SELECTION OIL QUANTITIES PAGE RHB-7	SELECTION GEARMOTORS PAGE RHB-49	DIMENSIONS PAGE RHB-92
----------------------------------	--	-------------------------------------	---------------------------



SELECTION/DIMENSIONS

RIGHT ANGLE HELICAL BEVEL REDUCER (RHB) Twin Tapered Bushing

SIZE: B_48

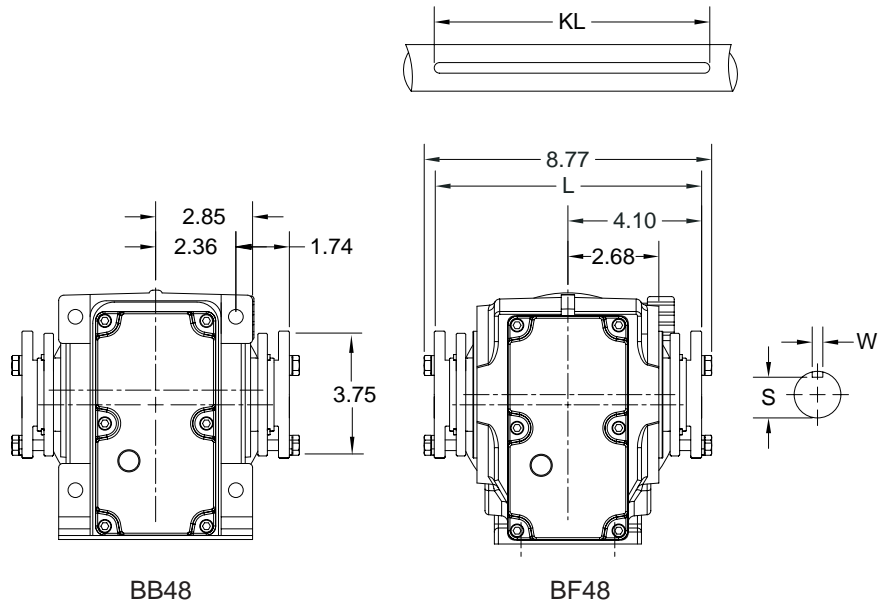

Part Number	RHB Size 48	Bore	Weight (lbs)	L	Part Number	RHB Size 48	Bore	Weight (lbs)	L	Shaft Keyseat		
										W	S	KL (3)
092593	Standard (1)	1.5000"	3.3	8.18"	---	---	---	---	5.66"	0.375"	1.289"	8.1875"
092594	Standard	1.4375"	3.6		092607	Short Shaft (2)	1.4375"	3.7		0.375"	1.225"	
092595	Standard	1.3750"	3.5		092608	Short Shaft	1.3750"	4.1		0.3125"	1.201"	
092596	Standard	1.3125"	3.8		092609	Short Shaft	1.3125"	4.0		0.3125"	1.137"	
092597	Standard	1.2500"	3.7		092610	Short Shaft	1.2500"	4.1		0.25"	1.112"	
092598	Standard	1.1875"	3.8		092611	Short Shaft	1.1875"	4.2		0.25"	1.049"	
092599	Standard	1.1250"	4.0		092612	Short Shaft	1.1250"	4.4		0.25"	0.986"	
092600	Standard	1.0625"	4.0		092613	Short Shaft	1.0625"	4.5		0.25"	0.923"	
092601	Standard	1.0000"	4.2		092614	Short Shaft	1.0000"	4.7		0.25"	0.859"	
092602	Standard	40 MM	3.3		---	---	---	---		12 mm	35 mm	
092603	Standard	38 MM	3.3		---	---	---	---		12 mm	33 mm	
092604	Standard	35 MM	3.6		092615	Short Shaft	35 MM	3.9		10 mm	30 mm	
092605	Standard	32 MM	3.8		092616	Short Shaft	32 MM	4.2		10 mm	27 mm	
092606	Standard	30 MM	3.8		092617	Short Shaft	30 MM	4.3		8 mm	26 mm	

- (1) - Standard Shaft Bushing Kit includes two standard bushings with two back-up plates and snap rings; hardware, and key.
- (2) - Short Shaft Bushing Kit includes one standard bushing, one long bushing with insertable wedge; two back-up plates with snap rings; hardware and key. This is an optional bushing for after market short shaft mounting.
- (3) - Standard key provided for Short Shaft Kit. Key will overhang customer shaft within bore.
- (---) - Bore Size not available.

Shaded Bore Sizes are Standard Non-Stock.

MOUNTING POSITIONS PAGE RHB-7	SELECTION OIL QUANTITIES PAGE RHB-7	SELECTION GEARMOTORS PAGE RHB-49	DIMENSIONS PAGE RHB-92
----------------------------------	--	-------------------------------------	---------------------------



SELECTION/DIMENSIONS

RIGHT ANGLE HELICAL BEVEL REDUCER (RHB) Twin Tapered Bushing

SIZE: B_68

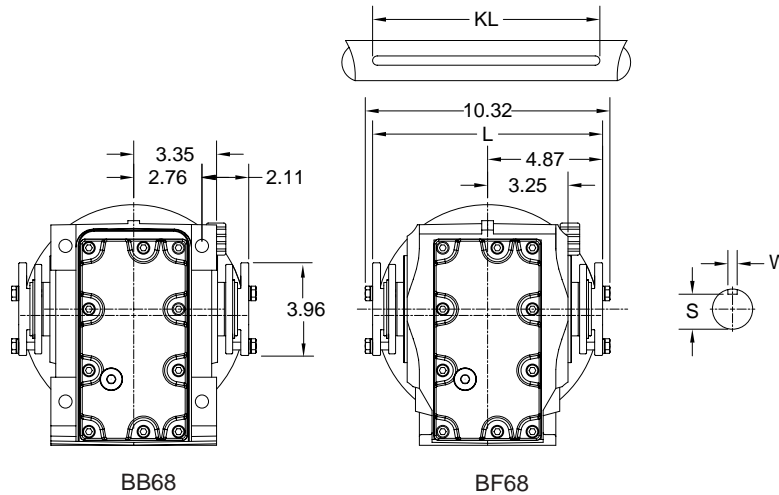

Part Number	RHB Size 68	Bore	Weight (lbs)	L	Part Number	RHB Size 68	Bore	Weight (lbs)	L	Shaft Keyseat			
										W	S	KL (3)	
093121	Standard (1)	1.8750"	5.0	9.73"	---	---	---	---	---	0.500"	1.591"	9.75"	
093122	Standard	1.7500"	5.0		---	---	---	---	---	---	0.375"		1.542"
093123	Standard	1.6875"	5.0		---	---	---	---	---	---	0.375"		1.479"
093124	Standard	1.6250"	5.0		---	---	---	---	---	---	0.375"		1.416"
093125	Standard	1.5000"	5.0		093132	Short Shaft (2)	1.5000"	5.0	7.25"	7.25"	0.375"		1.289"
093126	Standard	1.4375"	5.0		093133	Short Shaft	1.4375"	5.0			0.375"		1.225"
093127	Standard	1.3750"	5.0		093134	Short Shaft	1.3750"	5.0			0.3125"		1.201"
093128	Standard	1.3125"	5.0		093135	Short Shaft	1.3125"	5.0			0.3125"		"1.137"
093129	Standard	1.2500"	5.0		093136	Short Shaft	1.2500"	5.0			0.25"		1.112"
093130	Standard	1.1875"	5.0		093137	Short Shaft	1.1875"	5.0			0.25"		1.049"
093131	Standard	1.1250"	5.0		093138	Short Shaft	1.1250"	5.0			0.25"		0.986"
093139	Standard	45 MM	5.0		---	---	---	---			---		---
093140	Standard	42 MM	5.0		---	---	---	---	---	---	12 mm		37 mm
093141	Standard	40 MM	5.0		093146	Short Shaft	40 MM	5.0	7.25"	7.25"	12 mm		35 mm
093142	Standard	38 MM	5.0		093147	Short Shaft	38 MM	5.0			12 mm		33 mm
093143	Standard	35 MM	5.0	093148	Short Shaft	35 MM	5.0	10 mm			30 mm		
093144	Standard	32 MM	5.0	093149	Short Shaft	32 MM	5.0	10 mm			27 mm		
093145	Standard	30 MM	5.0	093150	Short Shaft	30 MM	5.0	8 mm			26 mm		

- (1) - Standard Shaft Bushing Kit includes two standard bushings with two back-up plates and snap rings; hardware, and key.
- (2) - Short Shaft Bushing Kit includes one standard bushing, one long bushing with insertable wedge; two back-up plates with snap rings; hardware and key. This is an optional bushing for after market short shaft mounting.
- (3) - Standard key provided for Short Shaft Kit. Key will overhang customer shaft within bore.
- (---) - Bore Size not available.

Shaded Bore Sizes are Standard Non-Stock.

MOUNTING POSITIONS PAGE RHB-7	SELECTION OIL QUANTITIES PAGE RHB-7	SELECTION GEARMOTORS PAGE RHB-49	DIMENSIONS PAGE RHB-92
----------------------------------	--	-------------------------------------	---------------------------



SELECTION/DIMENSIONS

RIGHT ANGLE HELICAL BEVEL REDUCER (RHB) Twin Tapered Bushing

SIZE: B_88

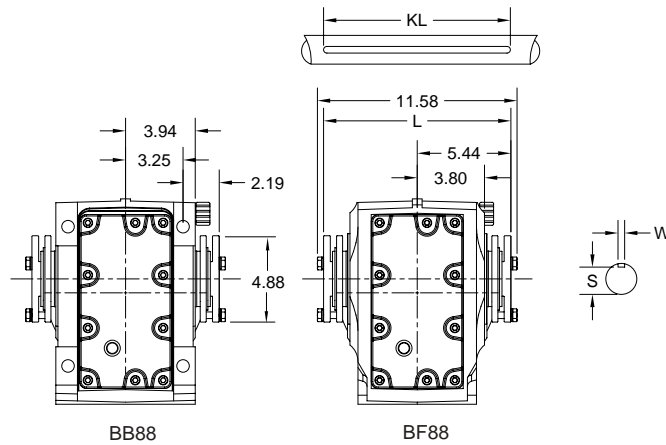

Part Number	RHB Size 88	Bore	Weight (lbs)	L	Part Number	RHB Size 88	Bore	Weight (lbs)	L	Shaft Keyseat		
										W	S	KL (3)
092619	Standard (1)	2.3750"	6.1	10.88"	---	---	---	---	---	0.625	2.021"	11.25"
092620	Standard	2.2500"	6.2		---	---	---	---	---	0.500"	1.893"	
092621	Standard	2.1875"	6.8		092631	Short Shaft (2)	2.1875"	7.0	7.54"	0.500"	1.909"	
092622	Standard	2.1250"	7.0		092632	Short Shaft	2.1250"	7.4		0.500"	1.845"	
092623	Standard	2.0000"	7.5		092633	Short Shaft	2.0000"	8.0		0.500"	1.718"	
092624	Standard	1.9375"	7.8		092634	Short Shaft	1.9375"	8.4		0.500"	1.655"	
092625	Standard	1.8750"	8.0		092635	Short Shaft	1.8750"	8.7		0.500"	1.591"	
092626	Standard	1.7500"	8.0		092636	Short Shaft	1.7500"	9.0		0.375"	1.542"	
092627	Standard	1.6875"	8.2		092637	Short Shaft	1.6875"	9.3		0.375"	1.479"	
092628	Standard	1.6250"	8.4		092638	Short Shaft	1.6250"	9.6		0.375"	1.416"	
092629	Standard	1.5000"	8.8		092639	Short Shaft	1.5000"	9.9		0.375"	1.289"	
092630	Standard	1.4375"	8.8		092640	Short Shaft	1.4375"	10.0		0.375"	1.225"	
092641	Standard	60 MM	6.2		---	---	---	---	---	18 mm	53 mm	
092642	Standard	55 MM	6.8		092649	Short Shaft	55 MM	7.1	7.54"	16 mm	49 mm	
092643	Standard	50 MM	7.5		092650	Short Shaft	50 MM	8.1		14 mm	44.5 mm	
092644	Standard	45 MM	8.1		092651	Short Shaft	45 MM	9.0		14 mm	39.5 mm	
092645	Standard	42 MM	8.4		092652	Short Shaft	42 MM	9.5		12 mm	37 mm	
092646	Standard	40 MM	8.6		092653	Short Shaft	40 MM	9.8		12 mm	35 mm	
092647	Standard	38 MM	8.8		092654	Short Shaft	38 MM	10.1		12 mm	33 mm	
092648	Standard	35 MM	9.0		092655	Short Shaft	35 MM	10.6		10 mm	30 mm	

- (1) - Standard Shaft Bushing Kit includes two standard bushings with two back-up plates and snap rings; hardware, and key.
- (2) - Short Shaft Bushing Kit includes one standard bushing, one long bushing with insertable wedge; two back-up plates with snap rings; hardware and key. This is an optional bushing for after market short shaft mounting.
- (3) - Standard key provided for Short Shaft Kit. Key will overhang customer shaft within bore.
- (---) - Bore Size not available.

Shaded Bore Sizes are Standard Non-Stock.

MOUNTING POSITIONS PAGE RHB-7	SELECTION OIL QUANTITIES PAGE RHB-7	SELECTION GEARMOTORS PAGE RHB-49	DIMENSIONS PAGE RHB-92
----------------------------------	--	-------------------------------------	---------------------------



SELECTION/DIMENSIONS

RIGHT ANGLE HELICAL BEVEL REDUCER (RHB) Twin Tapered Bushing

SIZE: B_108

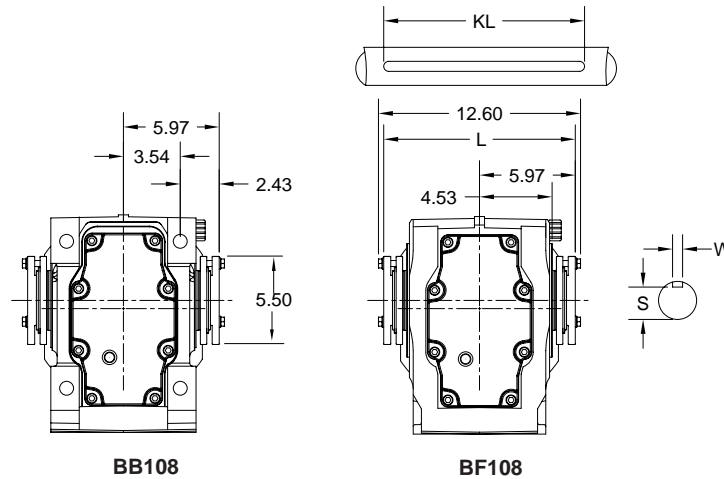

Part Number	RHB Size 108	Bore	Weight (lbs)	L	Part Number	RHB Size 108	Bore	Weight (lbs)	L	Shaft Keyseat			
										W	S	KL (3)	
092871	Standard (1)	2.6875"	9.4	11.72"	---	---	---	---	---	0.625"	2.338"	12.625"	
092872	Standard	2.5000"	10.6		---	---	---	---	---	---	0.625"		2.148"
092873	Standard	2.4375"	10.8		092883	Short Shaft (2)	2.4375"	11.3	8.45"	8.45"	0.625"		2.084"
092874	Standard	2.3750"	11.3		092884	Short Shaft	2.3750"	11.8			0.625"		2.021"
092875	Standard	2.2500"	11.5		092885	Short Shaft	2.2500"	12.4			0.500"		1.893"
092876	Standard	2.1875"	11.5		092886	Short Shaft	2.1875"	12.8			0.500"		1.909"
092877	Standard	2.1250"	12.2		092887	Short Shaft	2.1250"	13.3			0.500"		1.845"
092878	Standard	2.0000"	12.6		092888	Short Shaft	2.0000"	13.9			0.500"		1.718"
092879	Standard	1.9375"	13.0		092889	Short Shaft	1.9375"	14.3			0.500"		1.655"
092880	Standard	1.8750"	13.2		092890	Short Shaft	1.8750"	14.6			0.500"		1.591"
092881	Standard	1.7500"	13.3		092891	Short Shaft	1.7500"	15.0			0.375"		1.542"
092882	Standard	1.6875"	13.5		092892	Short Shaft	1.6875"	15.3			0.375"		1.479"
092893	Standard	70 MM	9.1		---	---	---	---	---	---	20 mm		62.5 mm
092894	Standard	65 MM	10.0		092900	Short Shaft	65 MM	10.4	8.45"	8.45"	18 mm		58 mm
092895	Standard	60 MM	11.2		092901	Short Shaft	60 MM	11.8			18 mm		53 mm
092896	Standard	55 MM	12.0		092902	Short Shaft	55 MM	13.0			16 mm		49 mm
092897	Standard	50 MM	12.6		092903	Short Shaft	50 MM	14.0			14 mm		44.5 mm
092898	Standard	45 MM	12.6		092904	Short Shaft	45 MM	15.1			14 mm		39.5 mm
092899	Standard	42 MM	13.7		092905	Short Shaft	42 MM	15.6			12 mm		37 mm

- (1) - Standard Shaft Bushing Kit includes two standard bushings with two back-up plates and snap rings; hardware, and key.
- (2) - Short Shaft Bushing Kit includes one standard bushing, one long bushing with insertable wedge; two back-up plates with snap rings; hardware and key.
This is an optional bushing for after market short shaft mounting.
- (3) - Standard key provided for Short Shaft Kit. Key will overhang customer shaft within bore.
- (---) - Bore Size not available.

Shaded Bore Sizes are Standard Non-Stock.

MOUNTING POSITIONS PAGE RHB-7	SELECTION OIL QUANTITIES PAGE RHB-7	SELECTION GEARMOTORS PAGE RHB-49	DIMENSIONS PAGE RHB-92
----------------------------------	--	-------------------------------------	---------------------------



SELECTION/DIMENSIONS

RIGHT ANGLE HELICAL BEVEL REDUCER (RHB) Twin Tapered Bushing

SIZE: B_128

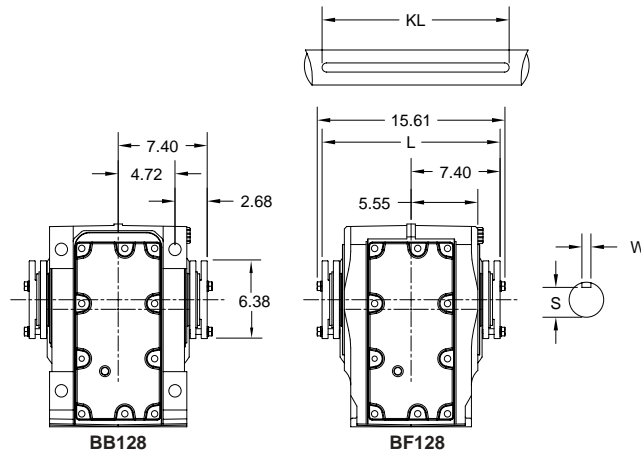

Part Number	RHB Size 128	Bore	Weight (lbs)	L	Part Number	RHB Size 128	Bore	Weight (lbs)	L	Shaft Keyseat			
										W	S	KL (3)	
092834	Standard (1)	3.1875"	13.7	14.94"	---	---	---	---	---	0.750"	2.768"	15.625"	
092835	Standard	3.0000"	15.1		---	---	---	---	---	0.750"	2.577"		
092836	Standard	2.9375"	15.6		092847	Short Shaft (2)	2.9375"	16.2	10.96"	0.750"	2.514"		
092837	Standard	2.8750"	16.1		092848	Short Shaft	2.8750"	16.9		0.750"	2.450"		
092838	Standard	2.6875"	16.7		092849	Short Shaft	2.6875"	18.1		0.625"	2.338"		
092839	Standard	2.5000"	17.9		092850	Short Shaft	2.5000"	19.7		0.625"	2.148"		
092840	Standard	2.4375"	18.1		092851	Short Shaft	2.4375"	20.1		0.625"	2.084"		
092841	Standard	2.3750"	18.3		092852	Short Shaft	2.3750"	20.5		0.625"	2.021"		
092842	Standard	2.2500"	18.9		092853	Short Shaft	2.2500"	21.4		0.500"	1.893"		
092843	Standard	2.1875"	19.1		092854	Short Shaft	2.1875"	21.8		0.500"	1.909"		
092844	Standard	2.1250"	19.3		092855	Short Shaft	2.1250"	22.2		0.500"	1.845"		
092845	Standard	2.0000"	19.9		092856	Short Shaft	2.0000"	23.0		0.500"	1.718"		
092846	Standard	1.9375"	20.1		092857	Short Shaft	1.9375"	23.4		0.500"	1.655"		
092858	Standard	80 MM	14.1		---	---	---	---		---	22 mm		71 mm
092859	Standard	75 MM	15.3		092865	Short Shaft	75 MM	15.8		10.96"	20 mm		67.5 mm
092860	Standard	70 MM	16.3		092866	Short Shaft	70 MM	17.4			20 mm		62.5 mm
092861	Standard	65 MM	17.5		092867	Short Shaft	65 MM	18.9			18 mm		58 mm
092862	Standard	60 MM	18.5		092868	Short Shaft	60 MM	21.7			18 mm		53 mm
092863	Standard	55 MM	19.3		092869	Short Shaft	55 MM	22.0	16 mm		49 mm		
092864	Standard	50 MM	19.9		092870	Short Shaft	50 MM	23.1	14 mm		44.5 mm		

- (1) - Standard Shaft Bushing Kit includes two standard bushings with two back-up plates and snap rings; hardware, and key.
- (2) - Short Shaft Bushing Kit includes one standard bushing, one long bushing with insertable wedge; two back-up plates with snap rings; hardware and key. This is an optional bushing for after market short shaft mounting.
- (3) - Standard key provided for Short Shaft Kit. Key will overhang customer shaft within bore.
- (---) - Bore Size not available.

Shaded Bore Sizes are Standard Non-Stock.

MOUNTING POSITIONS PAGE RHB-7	SELECTION OIL QUANTITIES PAGE RHB-7	SELECTION GEARMOTORS PAGE RHB-49	DIMENSIONS PAGE RHB-92
----------------------------------	--	-------------------------------------	---------------------------



SELECTION/DIMENSIONS

RIGHT ANGLE HELICAL BEVEL REDUCER (RHB) Twin Tapered Bushing

SIZE: B_148

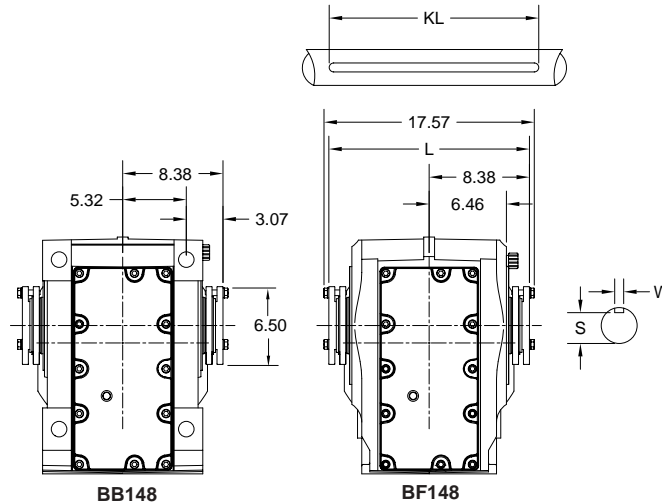

Part Number	RHB Size 148	Bore	Weight (lbs)	L	Part Number	RHB Size 148	Bore	Weight (lbs)	L	Shaft Keyseat			
										W	S	KL (3)	
093033	Standard (1)	3.4375"	16.1	17.23"	093044	Short Shaft (2)	3.4375"	16.5	13.15"	0.875"	2.943"	17.6875"	
093034	Standard	3.1875"	17.7		093045	Short Shaft	3.1875"	19.0		0.750"	2.768"		
093035	Standard	3.0000"	19.1		093046	Short Shaft	3.0000"	20.9		0.750"	2.577"		
093036	Standard	2.9375"	19.6		093047	Short Shaft	2.9375"	21.6		0.750"	2.514"		
093037	Standard	2.8750"	20.1		093048	Short Shaft	2.8750"	22.3		0.750"	2.450"		
093038	Standard	2.6875"	20.9		093049	Short Shaft	2.6875"	23.7		0.625"	2.338"		
093039	Standard	2.5000"	22.1		093050	Short Shaft	2.5000"	25.3		0.625"	2.148"		
093040	Standard	2.4375"	22.3		093051	Short Shaft	2.4375"	25.8		0.625"	2.084"		
093041	Standard	2.3750"	22.7		093052	Short Shaft	2.3750"	26.3		0.625"	2.021"		
093042	Standard	2.2500"	23.1		093053	Short Shaft	2.2500"	26.7		0.500"	1.893"		
093043	Standard	2.1875"	23.3		093054	Short Shaft	2.1875"	27.5		0.500"	1.909"		
093055	Standard	90 MM	14.9		---	---	---	---		---	25 mm		81 mm
093056	Standard	85 MM	16.4		093062	Short Shaft	85 MM	17.1		13.15"	22 mm		76 mm
093057	Standard	80 MM	18.1		093063	Short Shaft	80 MM	19.4			22 mm		71 mm
093058	Standard	75 MM	19.3		093064	Short Shaft	75 MM	21.2			20 mm		67.5 mm
093059	Standard	70 MM	20.4		093065	Short Shaft	70 MM	23.0			20 mm		62.5 mm
093060	Standard	65 MM	21.4		093066	Short Shaft	65 MM	24.0			18 mm		58 mm
093061	Standard	60 MM	22.6		093067	Short Shaft	60 MM	26.3			18 mm		53 mm

- (1) - Standard Shaft Bushing Kit includes two standard bushings with two back-up plates and snap rings; hardware, and key.
- (2) - Short Shaft Bushing Kit includes one standard bushing, one long bushing with insertable wedge; two back-up plates with snap rings; hardware and key.
This is an optional bushing for after market short shaft mounting.
- (3) - Standard key provided for Short Shaft Kit. Key will overhang customer shaft within bore.
- (---) - Bore Size not available.

Shaded Bore Sizes are Standard Non-Stock.

MOUNTING POSITIONS PAGE RHB-7	SELECTION OIL QUANTITIES PAGE RHB-7	SELECTION GEARMOTORS PAGE RHB-49	DIMENSIONS PAGE RHB-92
----------------------------------	--	-------------------------------------	---------------------------



SELECTION/DIMENSIONS

RIGHT ANGLE HELICAL BEVEL REDUCER (RHB) Twin Tapered Bushing

SIZE: B_168

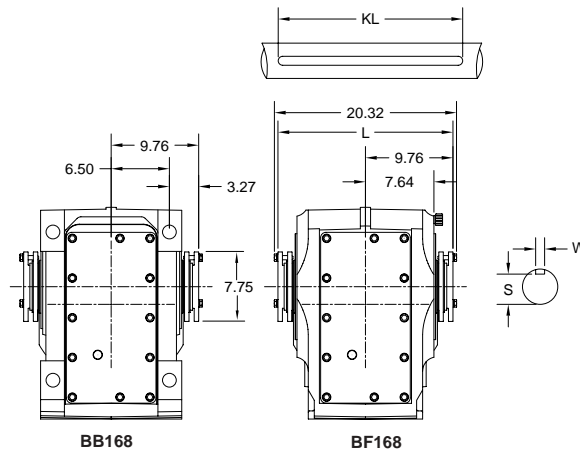

Part Number	RHB Size 168	Bore	Weight (lbs)	L	Part Number	RHB Size 168	Bore	Weight (lbs)	L	Shaft Keyseat			
										W	S	KL (3)	
093068	Standard (1)	4.4375"	20.5	20.23"	---	---	---	---	---	1.000"	3.880"	20.5625"	
093069	Standard	4.1875"	23.5		---	---	---	---	---	---	1.000"		3.627"
093070	Standard	3.9375"	26.3		093079	Short Shaft (2)	3.9375"	26.7	15.51"	1.000"	3.373"		
093071	Standard	3.4375"	30.9		093080	Short Shaft	3.4375"	34.2	0.875"	2.943"			
093072	Standard	3.1875"	32.6		093081	Short Shaft	3.1875"	36.7	0.750"	2.768"			
093073	Standard	3.0000"	34.0		093082	Short Shaft	3.0000"	38.8	0.750"	2.577"			
093074	Standard	2.9375"	34.6		093083	Short Shaft	2.9375"	39.6	0.750"	2.514"			
093075	Standard	2.8750"	35.0		093084	Short Shaft	2.8750"	40.2	0.750"	2.450"			
093076	Standard	2.6875"	35.8		093085	Short Shaft	2.6875"	41.7	0.625"	2.338"			
093077	Standard	2.5000"	37.2		093086	Short Shaft	2.5000"	43.6	0.625"	2.148"			
093078	Standard	2.4375"	37.4		093087	Short Shaft	2.4375"	44.1	0.625"	2.084"			
093088	Standard	110 MM	21.4		---	---	---	---	---	28 mm	100 mm		
093089	Standard	100 MM	25.9		093097	Short Shaft	100 MM	27.1	15.51"	28 mm	90 mm		
093090	Standard	95 MM	27.8		093098	Short Shaft	95 MM	29.8	25 mm	86 mm			
093091	Standard	90 MM	29.7		093099	Short Shaft	90 MM	32.5	25 mm	81 mm			
093092	Standard	85 MM	31.1		093100	Short Shaft	85 MM	34.6	22 mm	76 mm			
093093	Standard	80 MM	32.7		093101	Short Shaft	80 MM	37.0	22 mm	71 mm			
093094	Standard	75 MM	33.9		093102	Short Shaft	75 MM	39.0	20 mm	67.5 mm			
093095	Standard	70 MM	35.3		093103	Short Shaft	70 MM	41.1	20 mm	62.5 mm			
093096	Standard	65 MM	36.5		093104	Short Shaft	65 MM	42.8	18 mm	58 mm			

- (1) - Standard Shaft Bushing Kit includes two standard bushings with two back-up plates and snap rings; hardware, and key.
- (2) - Short Shaft Bushing Kit includes one standard bushing, one long bushing with insertable wedge; two back-up plates with snap rings; hardware and key. This is an optional bushing for after market short shaft mounting.
- (3) - Standard key provided for Short Shaft Kit. Key will overhang customer shaft within bore.
- (---) - Bore Size not available.

Shaded Bore Sizes are Standard Non-Stock.

MOUNTING POSITIONS PAGE RHB-7	SELECTION OIL QUANTITIES PAGE RHB-7	SELECTION GEARMOTORS PAGE RHB-49	DIMENSIONS PAGE RHB-92
----------------------------------	--	-------------------------------------	---------------------------



SELECTION/DIMENSIONS

Screw Conveyor Shaft Mount Speed Reducer RHB 38 Screw Conveyor Drive

SIZE: BF38

Complete drive consists of reducer, CEMA drive shaft and adapter assembly. Drive is shipped unassembled.

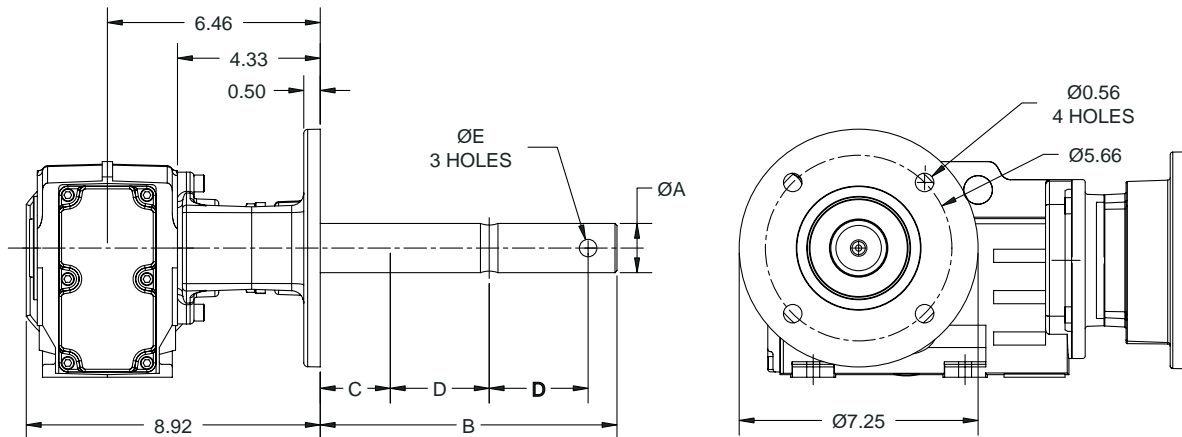

CEMA Drive Shafts								
Drive Shaft	Screw Dia.	Part No.	ØA	B	C	D	ØE	Weight (lbs)
1.5" Standard	6" - 9"	091583	1.50	9.00	2.13	3.00	0.53	8.0

	Part No.	Weight
Standard Adapter Assembly	091698	11.1
Severe Duty Package	091699	1.0

Notes:

Screw conveyor option is for use with the standard inch straight bore hollow shaft (1.250").

Severe Duty option includes packing retainer, stud and nut and a braided felt seal.

The RHB 38 is designed to handle 867 pounds thrust at the output bearings.

Reference page RHB-116 - RHB-123 for dimensions of gearcase and input options.

MOUNTING POSITIONS PAGE RHB-7	SELECTION OIL QUANTITIES PAGE RHB-7	SELECTION GEARMOTORS PAGE RHB-49	DIMENSIONS PAGE RHB-92
----------------------------------	--	-------------------------------------	---------------------------



SELECTION/DIMENSIONS

Screw Conveyor Shaft Mount Speed Reducer RHB 48 Screw Conveyor Drive

SIZE: BF48

Complete drive consists of reducer, CEMA drive shaft and adapter assembly. Drive is shipped unassembled.

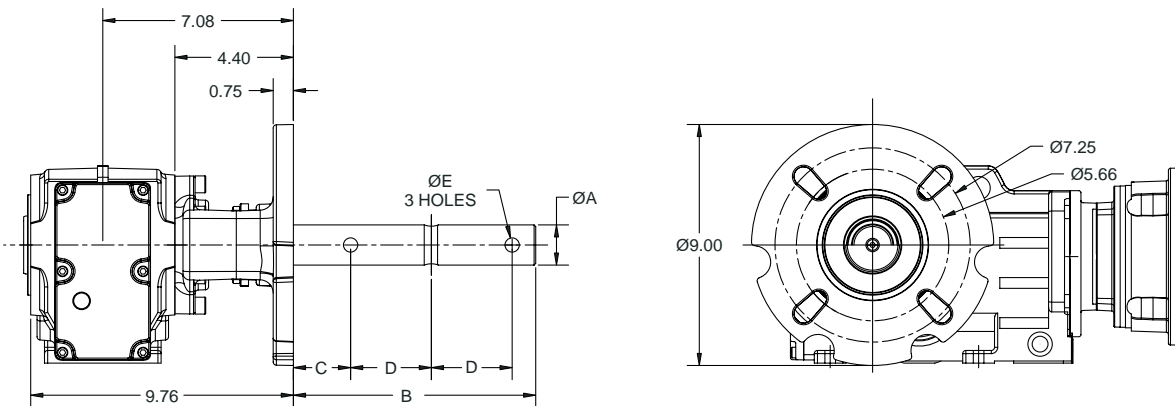

CEMA Drive Shafts								
Drive Shaft	Screw Dia.	Part No.	ØA	B	C	D	ØE	Weight (lbs)
1.5" Standard	6" - 9"	091585	1.50	9.00	2.13	3.00	0.53	9.4
2" Standard	9" - 12"	091587	2.00	9.00	2.13	3.00	0.66	12.8

	Part No.	Weight
Standard Adapter Assembly	091700	19.3
Severe Duty Package	091701	1.5

Notes:

Screw conveyor option is for use with the standard inch straight bore hollow shaft (1.375").

Severe Duty option includes packing retainer, stud and nut and a braided felt seal.

The RHB 48 is designed to handle 2267 pounds thrust at the output bearings.

Reference page RHB-148 - RHB-155 for dimensions of gearcase and input options.

MOUNTING POSITIONS PAGE RHB-7	SELECTION OIL QUANTITIES PAGE RHB-7	SELECTION GEARMOTORS PAGE RHB-49	DIMENSIONS PAGE RHB-92
----------------------------------	--	-------------------------------------	---------------------------



SELECTION/DIMENSIONS

Screw Conveyor Shaft Mount Speed Reducer RHB 68 Screw Conveyor Drive

SIZE: BF68

Complete drive consists of reducer, CEMA drive shaft and adapter assembly. Drive is shipped unassembled.

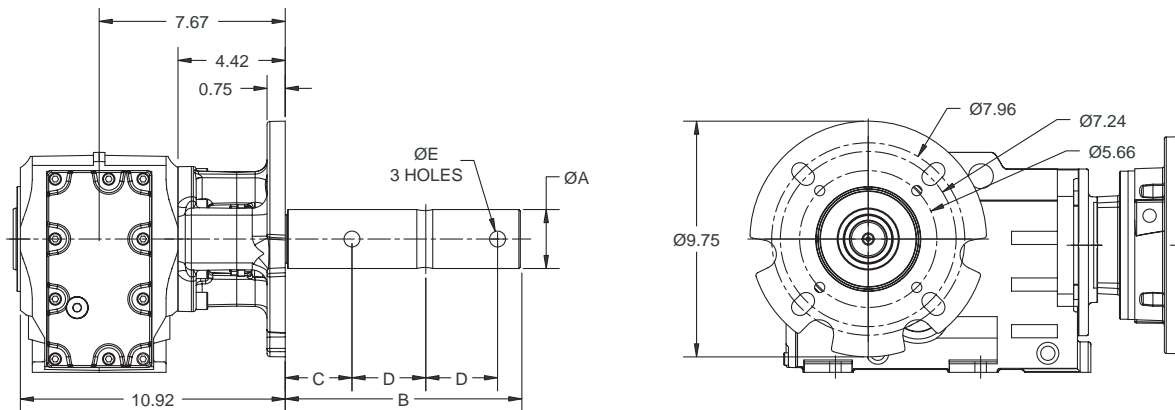

CEMA Drive Shafts								
Drive Shaft	Screw Dia.	Part No.	ØA	B	C	D	ØE	Weight (lbs)
1.5" Standard	6" - 9"	091589	1.50	9.00	2.13	3.00	0.53	10.5
2" Standard	9" - 12"	091591	2.00	9.00	2.13	3.00	0.66	13.8
2.4375" Standard	12" - 14"	091593	2.4375	9.69	2.75	3.00	0.66	18.6

	Part No.	Weight
Standard Adapter Assembly	091702	22.0
Severe Duty Package	091703	1.5

Notes:

Screw conveyor option is for use with the standard inch straight bore hollow shaft (1.50").

Severe Duty option includes packing retainer, stud and nut and a braided felt seal.

The RHB 68 is designed to handle 3067 pounds thrust at the output bearings.

Reference page RHB-180 - RHB-187 for dimensions of gearcase and input options.

MOUNTING POSITIONS PAGE RHB-7	SELECTION OIL QUANTITIES PAGE RHB-7	SELECTION GEARMOTORS PAGE RHB-49	DIMENSIONS PAGE RHB-92
----------------------------------	--	-------------------------------------	---------------------------



SELECTION/DIMENSIONS

Screw Conveyor Shaft Mount Speed Reducer RHB 88 Screw Conveyor Drive

SIZE: BF88

Complete drive consists of reducer, CEMA drive shaft and adapter assembly. Drive is shipped unassembled.

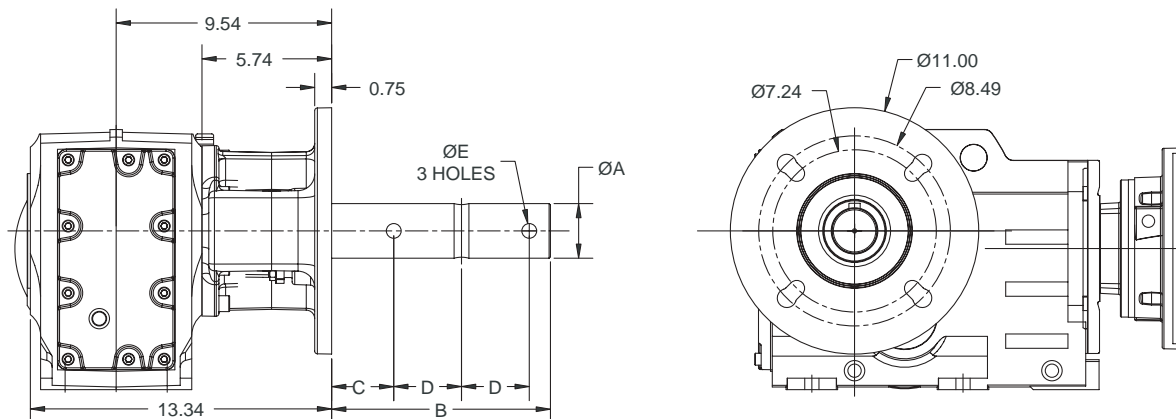

CEMA Drive Shafts								
Drive Shaft	Screw Dia.	Part No.	ØA	B	C	D	ØE	Weight (lbs)
2" Standard	9" - 12"	091597	2.00	9.00	2.13	3.00	0.66	22.3
2.4375" Standard	12" - 14"	091599	2.4375	9.69	2.75	3.00	0.66	27.1
3" Standard	12" - 20"	091601	3.00	9.87	2.87	3.00	0.78	33.7

	Part No.	Weight
Standard Adapter Assembly	091704	39.6
Severe Duty Package	091705	2.3

Notes:

Screw conveyor option is for use with the standard inch straight bore hollow shaft (2.00").

Severe Duty option includes packing retainer, stud and nut and a braided felt seal.

The RHB 88 is designed to handle 4000 pounds thrust at the output bearings.

Reference page RHB-212 - RHB-219 for dimensions of gearcase and input options.

MOUNTING POSITIONS PAGE RHB-7	SELECTION OIL QUANTITIES PAGE RHB-7	SELECTION GEARMOTORS PAGE RHB-49	DIMENSIONS PAGE RHB-92
----------------------------------	--	-------------------------------------	---------------------------



SELECTION/DIMENSIONS

Screw Conveyor Shaft Mount Speed Reducer RHB 108 Screw Conveyor Drive

SIZE: BF108

Complete drive consists of reducer, CEMA drive shaft and adapter assembly. Drive is shipped unassembled.

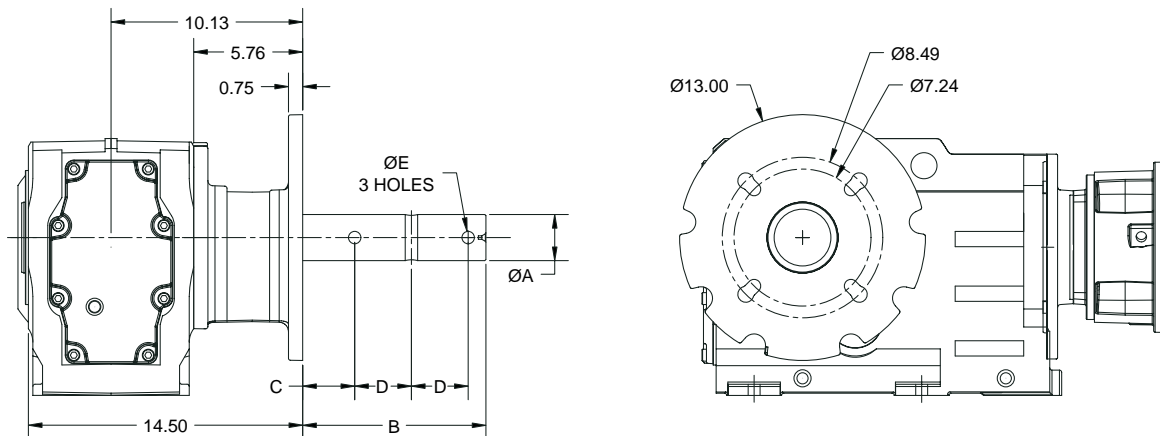

CEMA Drive Shafts								
Drive Shaft	Screw Dia.	Part No.	ØA	B	C	D	ØE	Weight (lbs)
2" Standard	9" - 12"	091603	2.00	9.00	2.13	3.00	0.66	27.2
2.4375" Standard	12" - 14"	091605	2.4375	9.69	2.75	3.00	0.66	32.1
3" Standard	12" - 20"	091607	3.00	9.87	2.87	3.00	0.78	38.8

	Part No.	Weight
Standard Adapter Assembly	091706	58.2
Severe Duty Package	091707	2.1

Notes:

Screw conveyor option is for use with the standard inch straight bore hollow shaft (2.375").

Severe Duty option includes packing retainer, stud and nut and a braided felt seal.

The RHB 108 is designed to handle 4667 pounds thrust at the output bearings.

Reference page RHB-244 - RHB-251 for dimensions of gearcase and input options.

MOUNTING POSITIONS PAGE RHB-7	SELECTION OIL QUANTITIES PAGE RHB-7	SELECTION GEARMOTORS PAGE RHB-49	DIMENSIONS PAGE RHB-92
----------------------------------	--	-------------------------------------	---------------------------



SELECTION/DIMENSIONS

Screw Conveyor Shaft Mount Speed Reducer RHB 128 Screw Conveyor Drive

SIZE: BF128

Complete drive consists of reducer, CEMA drive shaft and adapter assembly. Drive is shipped unassembled.

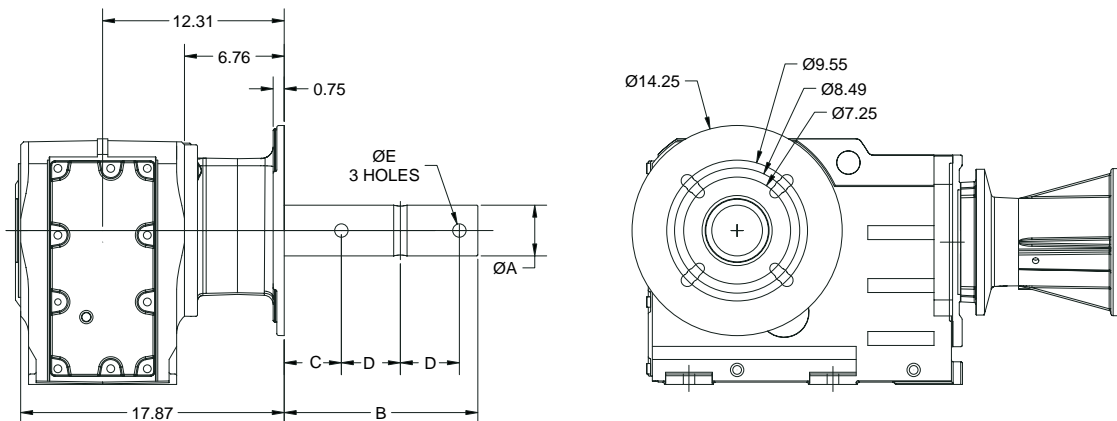

CEMA Drive Shafts								
Drive Shaft	Screw Dia.	Part No.	ØA	B	C	D	ØE	Weight (lbs)
2" Standard	9" - 12"	091609	2.00	9.00	2.13	3.00	0.66	43.4
2.4375" Standard	12" - 14"	091611	2.4375	9.69	2.75	3.00	0.66	48.2
3" Standard	12" - 20"	091613	3.00	9.87	2.87	3.00	0.78	54.9
3.4375" Standard	18" - 20"	091615	3.4375	13.13	3.87	4.00	0.91	69.4

	Part No.	Weight
Standard Adapter Assembly	091708	88.4
Severe Duty Package	091709	3.1

Notes:

Screw conveyor option is for use with the standard inch straight bore hollow shaft (2.750").
 Severe Duty option includes packing retainer, stud and nut and a braided felt seal.
 The RHB 128 is designed to handle 6000 pounds thrust at the output bearings.
 Reference page RHB-276 - RHB-283 for dimensions of gearcase and input options.

MOUNTING POSITIONS PAGE RHB-7	SELECTION OIL QUANTITIES PAGE RHB-7	SELECTION GEARMOTORS PAGE RHB-49	DIMENSIONS PAGE RHB-92
----------------------------------	--	-------------------------------------	---------------------------