

INSTRUCTION MANUAL

for 5⁷/₁₆" to 7" BORE DODGE® TYPE E BEARINGS

INSTALLATION INSTRUCTIONS

WARNING

To ensure that drive is not unexpectedly started, turn off and lock out or tag power source before proceeding. Failure to observe these precautions could result in bodily injury.

1. Clean shaft and bore of bearing. Lubricate with light oil or antiseize compound.
2. Slip bearing into position.
3. Bolt bearing to support, using shims where necessary to align bearing. The effort required to turn the shaft should be the same before and after bolting bearing to the support.
4. Tighten set screws to the torque values shown in Table 1.

TABLE 1
Set Screw Torque

Size	In.-Lbs.
3/4	2150
7/8	5130

LUBRICATION INSTRUCTIONS

Storage or Special Shutdown – If exposed to wet or dusty conditions or to corrosive vapors, extra protection is necessary: Add grease until it shows at the seals; rotate the bearing to distribute grease; cover the bearing. After storage or idle period, add a little fresh grease before running.

High Speed Operation – In the higher speed ranges too much grease will cause overheating. The amount of grease that the bearing will take for a particular high speed application can only be determined by experience – see “Operating Temperature” below. If excess grease in the bearing causes overheating, it will be necessary to remove grease fitting (also drain plug when furnished) to permit excess grease to escape. The bearing has been greased at the factory and is ready to run. When establishing a relubrication schedule, note that a small amount of grease at frequent intervals is preferable to a large amount at infrequent intervals.

Operation in Presence of Dust, Water or Corrosive Vapors – Under these conditions the bearing should contain as much grease as speed will permit, since a full bearing with consequent slight leakage is the best protection against entrance of foreign material. In the higher speed ranges too much grease will cause overheating – see “High Speed

Operation.” In the lower speed ranges it is advisable to add extra grease to a new bearing before putting into operation. Bearings should be greased as often as necessary (daily if required) to maintain a slight leakage at the seals.

Average Operation – This bearing has been greased at the factory and is ready to run. The following table is a general guide for relubrication. However, certain conditions may require a change of lubricating periods as dictated by experience. See “High Speed Operation” and “Operation in Presence of Dust, Water or Corrosive Vapors.”

Lubrication Guide

Read Preceding Paragraphs Before Establishing Lubrication Schedule.

Hours Run per Day	Suggested Lubrication Period in Weeks				
	1 to 250 RPM	251 to 500 RPM	501 to 750 RPM	751 to 1000 RPM	1001 to 1500 RPM
8	12	12	10	7	5
16	12	7	5	4	2
24	10	5	3	2	1

Operating Temperature – Abnormal bearing temperature may indicate faulty lubrication. Normal temperature may range from “cool to warm to the touch” up to a point “too hot to touch for more than a few seconds,” depending on bearing size and speed, and surrounding conditions. Unusually high temperature accompanied by excessive leakage of grease indicates too much grease. High temperature with no grease showing at the seals, particularly if the bearing seems noisy, usually indicates too little grease. Normal temperature and a slight showing of grease at the seals indicate proper lubrication.

Kind of Grease – Many ordinary cup greases will disintegrate at speeds far below those at which DODGE bearings will operate successfully if proper grease is used. DODGE bearings have been lubricated at the factory with No. 2 consistency lithium base grease which is suitable for normal operating conditions. Relubricate with lithium base grease or a grease which is compatible with original lubricant and suitable for roller bearing service. In unusual or doubtful cases the recommendation of a reputable grease manufacturer should be secured.

Special Operating Conditions – Refer acid, chemical, extreme or other special operating conditions to DODGE/Reliance Industrial Company, Greenville, S.C.

WARNING: Because of the possible danger to person(s) or property from accidents which may result from the improper use of products, it is important that correct procedures be followed: Products must be used in accordance with the engineering information specified in the catalog. Proper installation, maintenance and operation procedures must be observed. The instructions in the instruction manuals must be followed. Inspections should be made as necessary to assure safe operation under prevailing conditions. Proper guards and other suitable safety devices or procedures as may be desirable or as may be specified in safety codes should be provided, and are neither provided by Reliance Industrial Company nor are the responsibility of Reliance Industrial Company. This unit and its associated equipment must be installed, adjusted and maintained by qualified personnel who are familiar with the construction and operation of all equipment in the system and the potential hazards involved. When risk to persons or property may be involved, a holding device must be an integral part of the driven equipment beyond the speed reducer output shaft.

DODGE/P.O. Box 499/6040 Ponders Court/Greenville, SC 29602-0499/803-297-4800

© Reliance Company, 1991 DODGE is a registered trademark of Reliance Company or its affiliates.



Printed in U.S.A.

Instruction Manual 499793

04/07 25M-K

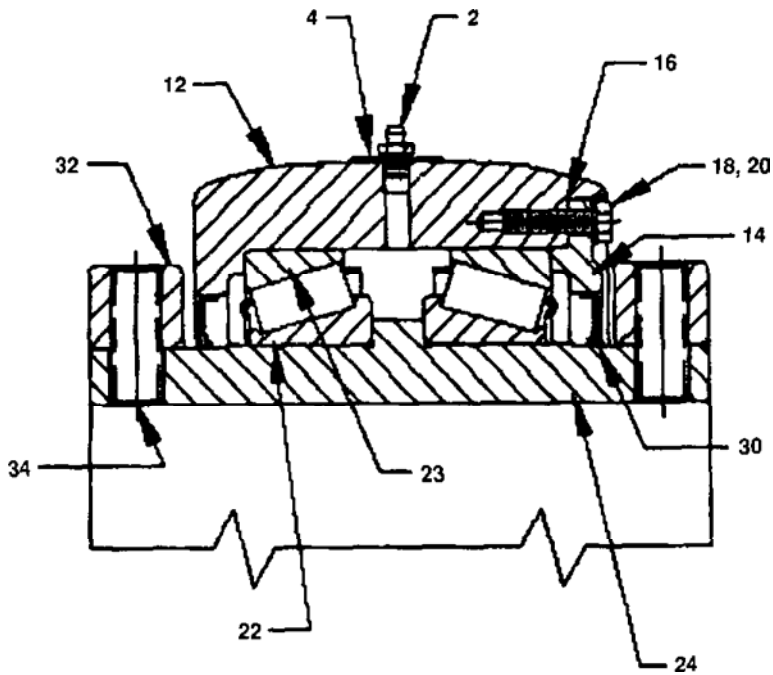

NOTE: The two-digit numbers are for reference only. Order parts by the six-digit part numbers. Each six-digit number is a complete identification of the part or assembly.

Parts for 5 7/16" to 7" Type E Bearing

Reference	Name of Part	No. Req'd.	Part Numbers						
			5 7/16	5 15/16	6	6 7/16	6 1/2	6 15/16	7
2	Lubrication Fitting	1	405015	405015	405015	405015	405015	405015	405015
4	Name Plate	1	404052	404052	404052	404052	404052	404052	404052
12	Pillow Block Housing 4B	1	060039	060039	060039	060040	060040	060040	060040
14	Pillow Block End Plate	1	060046	060046	060046	060047	060047	060047	060047
16	End Plate Shim Pack	1 Set*	391108	391108	391108	391109	391109	391109	391109
	.020" Thick Shim	1	427061	427061	427061	427062	427062	427062	427062
	.010" Thick Shim	1	427063	427063	427063	427066	427066	427066	427066
	.005" Thick Shim	1	427064	427064	427064	427067	427067	427067	427067
	.002" Thick Shim	1	427065	427065	427065	427068	427068	427068	427068
18	End Plate Screw	8	411579	411579	411579	411581	411581	411581	411581
20	End Plate Lockwasher	8	419010	419010	419010	419011	419011	419011	419011
22	Cone	2	391826	391826	391826	391828	391828	391828	391828
23	Cup	2	391827	391827	391827	391829	391829	391829	391829
24	Bearing Sleeve 65° S.S. Angle	1	059960	059961	059962	059963	059964	059965	059966
30	Seal, Single Lip	2	061366	061366	061366	061367	061367	061367	061367
32	Collar (65° S.S. Angle)	2	042726	042726	042726	042727	042727	042727	042727
34	Collar Screw	4	400238	400234	400234	400252	400252	400251	400251

* One set consists of the shims listed immediately below.

Shaft Tolerances: 5 7/16" to 6" +.0000-.0015
 6 7/16" to 7" +.0000-.0020